

# *Larson Systems Inc.*

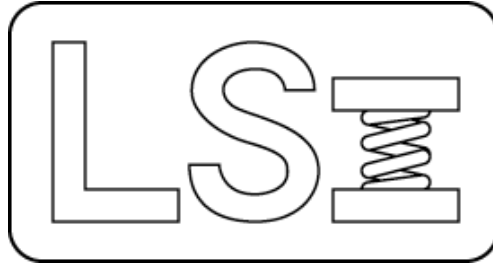

## *STAR 25 Parts List*

*050-0000-0093-00*





# 050-0000-0093-00 H

# Parts List

## STAR - Flash Control Base Unit - 25" Stroke

Rev	By	Date	Description
E	KMP	08-18-2006	Update to Flash Changes Item 3 was 25-0-0023-09, Item 5 was 25-2-0088-00. Delete P/N 25-2-0088-01 Item 5
F	KMP	12-12-2007	Change Name to 1,000 lb, Update to Servo Drive Change. Change Item 5 was 025-2-0029-00
F	DAL	08-08-2008	delete load cell options, listed on quote form 500-2000-0007-00
G	DAL	03-28-2012	Update Schematic was 025-2000-00160-05 and 025-2000-0160-07 and 025-2000-0160-11, is 025-2000-0165-03

Item	Qty	Part Number	Rev	Part Name	PCB Location	Part Length
1	1	025-0000-0422-00	N	STAR 25, Stand Alone Assembly		in.
2	1	025-0000-0431-10	C	FLASH - Computer Assembly		in.
3	1	025-6000-0013-00	D	Sticker Assembly - STAR 25"		in.
4	1	025-2000-0165-03	E	Schematic, Flash Robo-STAR 24-X000, Attached		in.
5	1	060-1000-0066-01	A	User Manual - STAR and RoboSTAR		in.
6	1	059-0000-0040-01		Shipping Crate - STAR 25		in.
7	1	060-2000-0004-01	A	Parts List - STAR 24" Stroke		in.
8	1	060-6000-0114-00		FLASH : System Image Creation Letter		in.

Approved by: \_\_\_\_\_

Date: \_\_\_\_\_

REV	DATE	DESCRIPTION	DRW	APP
		SEE SHEET 6		

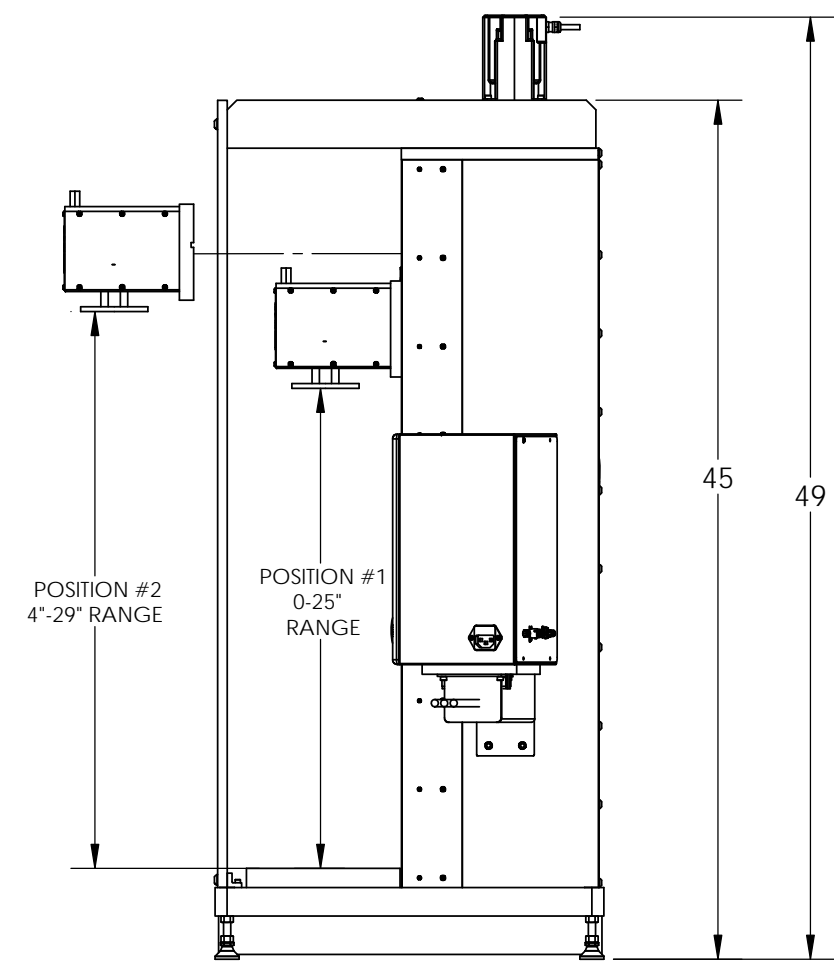
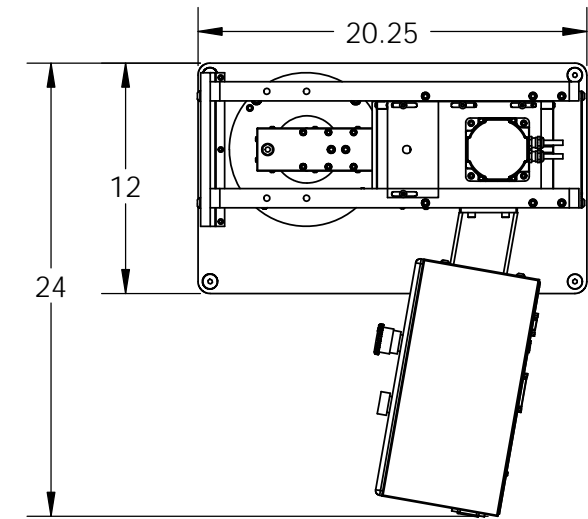
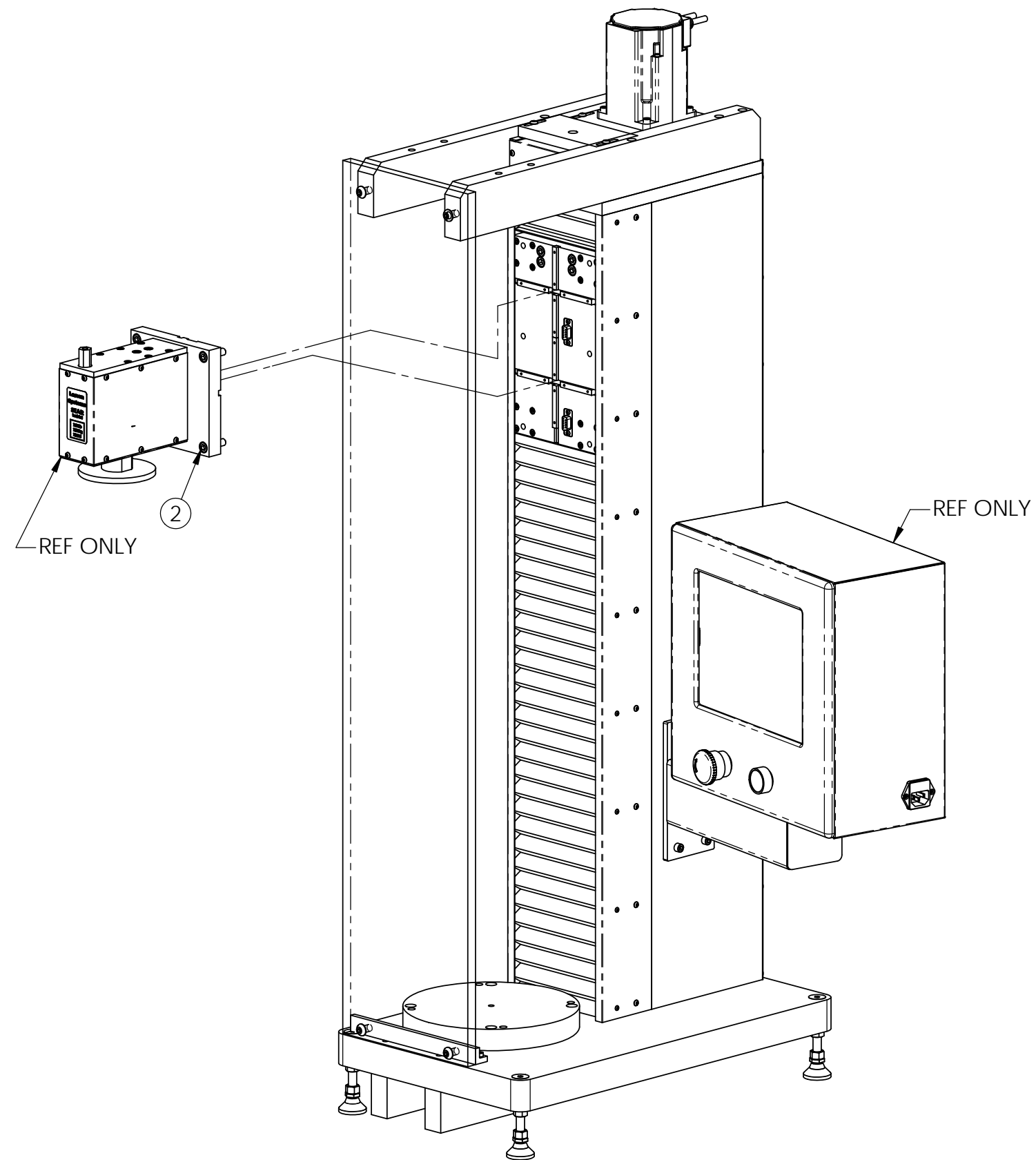

UNLESS OTHERWISE SPECIFIED  
DIMENSIONS ARE IN INCHES  
TOLERANCES ARE:  
.XX ± .01  
.XXX ± .005

MATERIAL

FINISH

HEAT TREAT

		APPROVALS	DATE
		DRAWN MEM	6-18-03
APPR.			
APPR.			

**LARSON SYSTEMS INC.**  
10073 Baltimore St. NE PH. 763-780-2131  
Mpls., MN 55449 FAX. 763-780-2182

STAR 24 STAND ALONE ASSEMBLY

DWG. NO. B 025-0000-0422-00N

SCALE: NONE

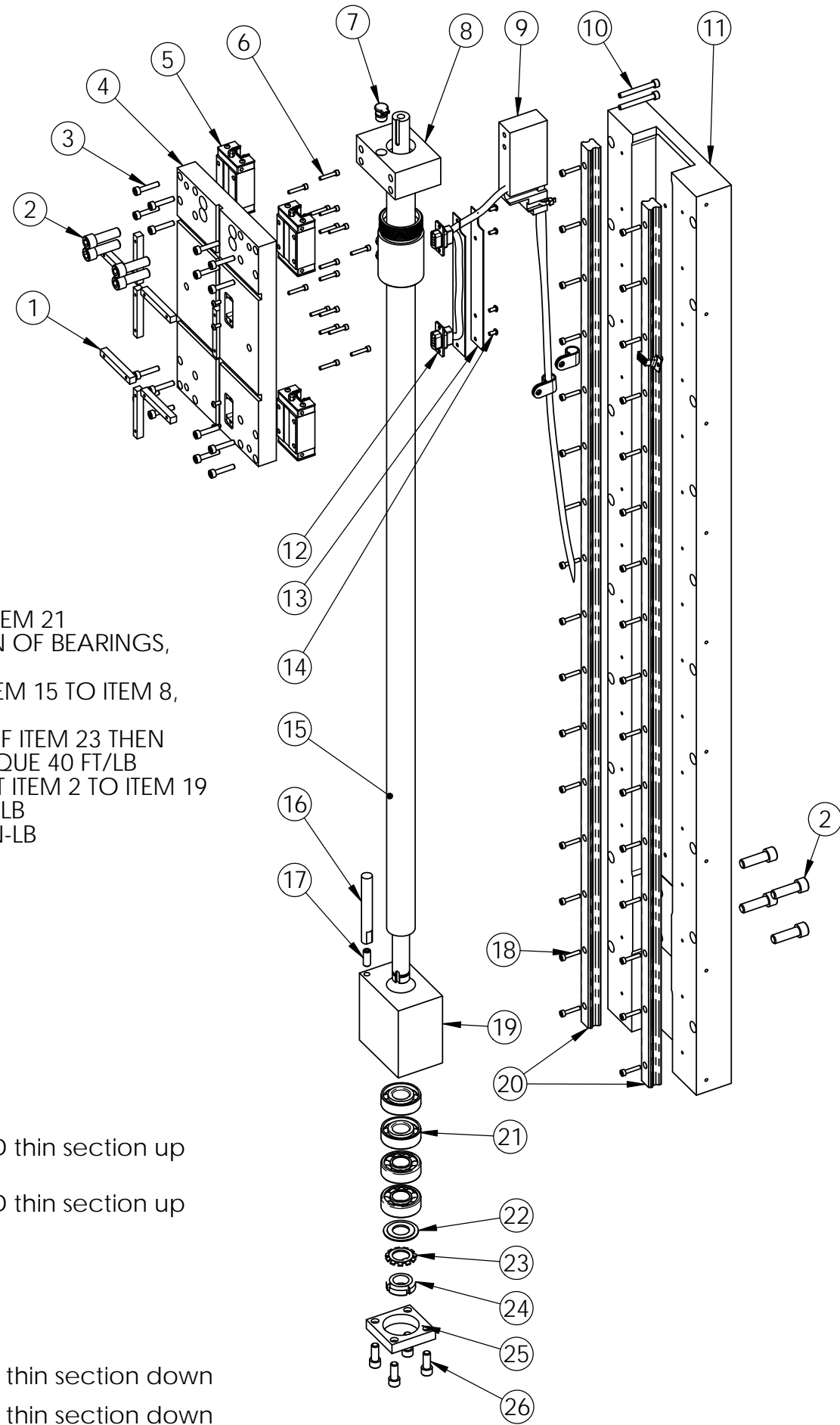

NOTES:

1. GREASE BEARINGS, ITEM 21
2. NOTICE ORIENTATION OF BEARINGS, ITEM 21
3. TIGHTEN BALL NUT, ITEM 15 TO ITEM 8, TORQUE 40 FT/LB
4. GREASE SURFACES OF ITEM 23 THEN FASTEN ITEM 24, TORQUE 40 FT/LB
5. TIGHTEN FINGERTIGHT ITEM 2 TO ITEM 19
6. #3 TORQUE TO 22 IN-LB
7. #18 TORQUE TO 14 IN-LB

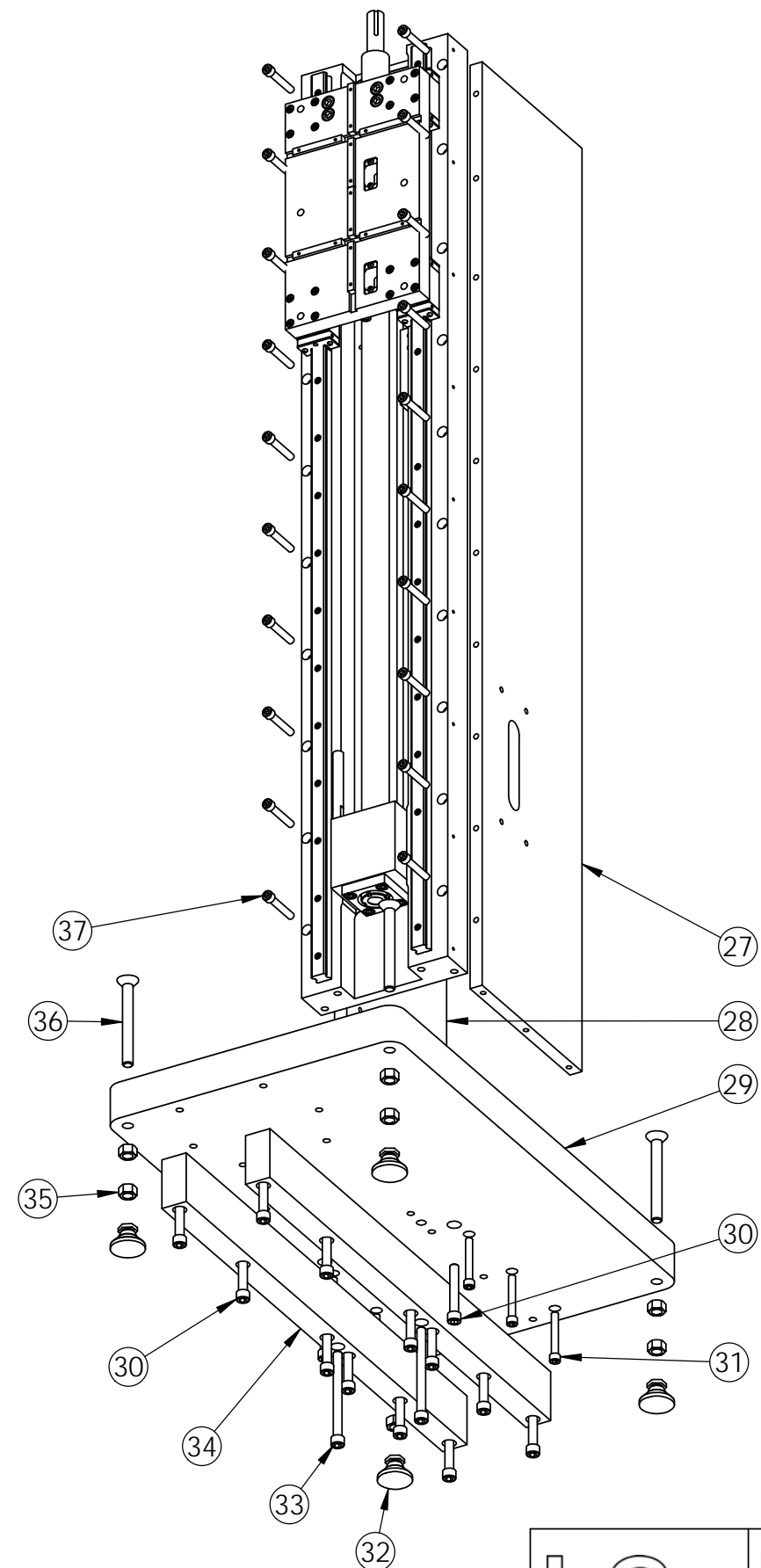
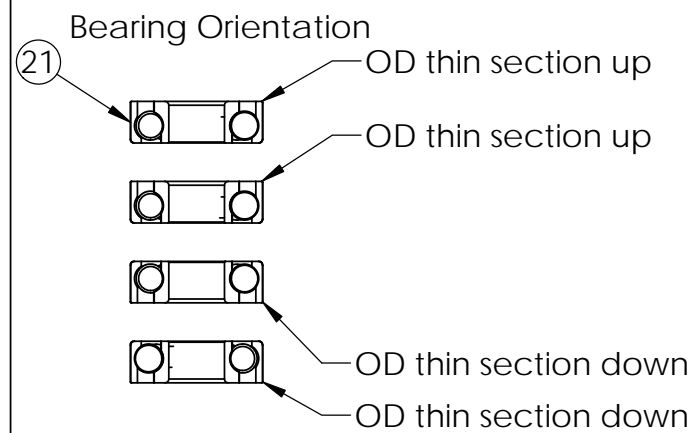

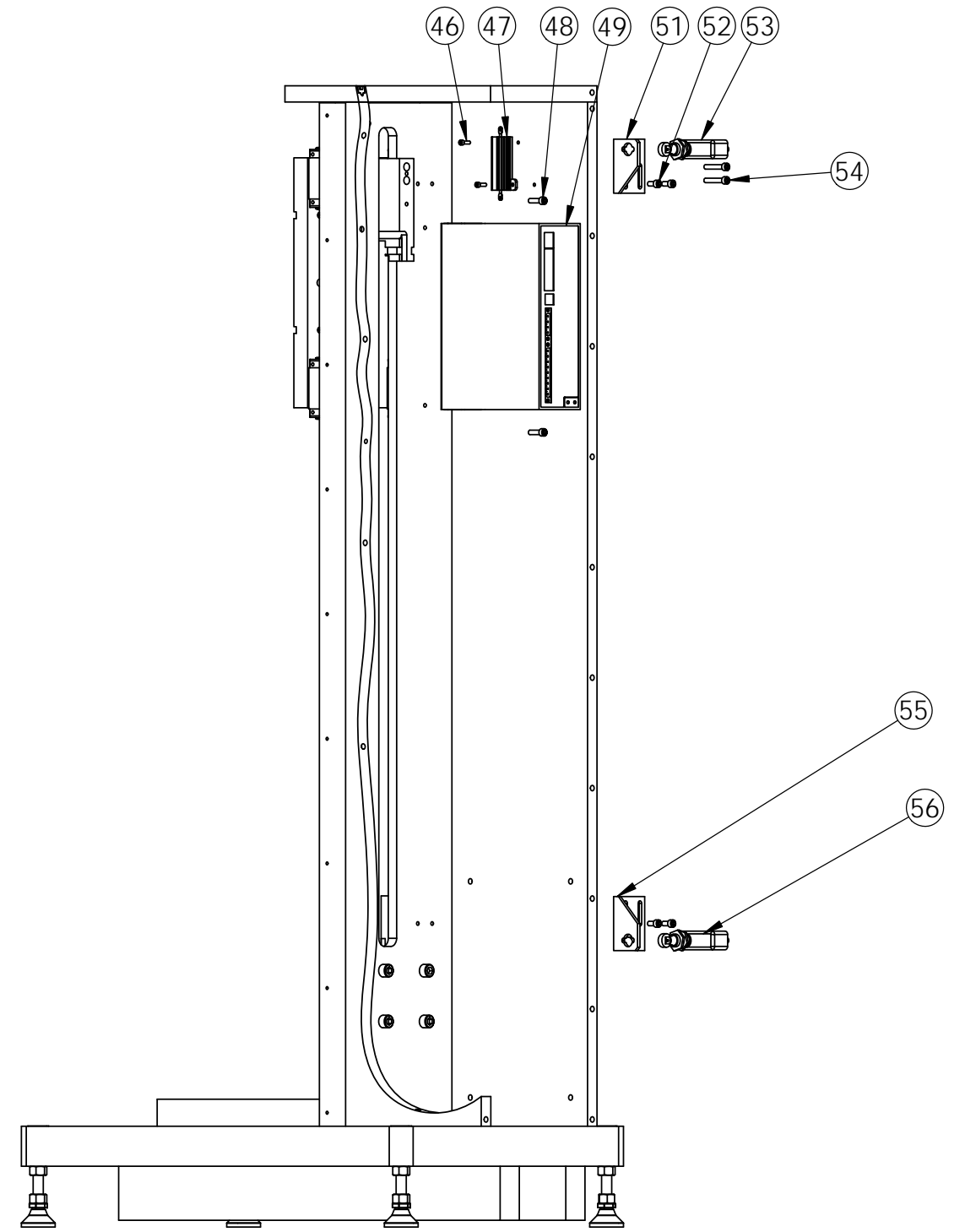
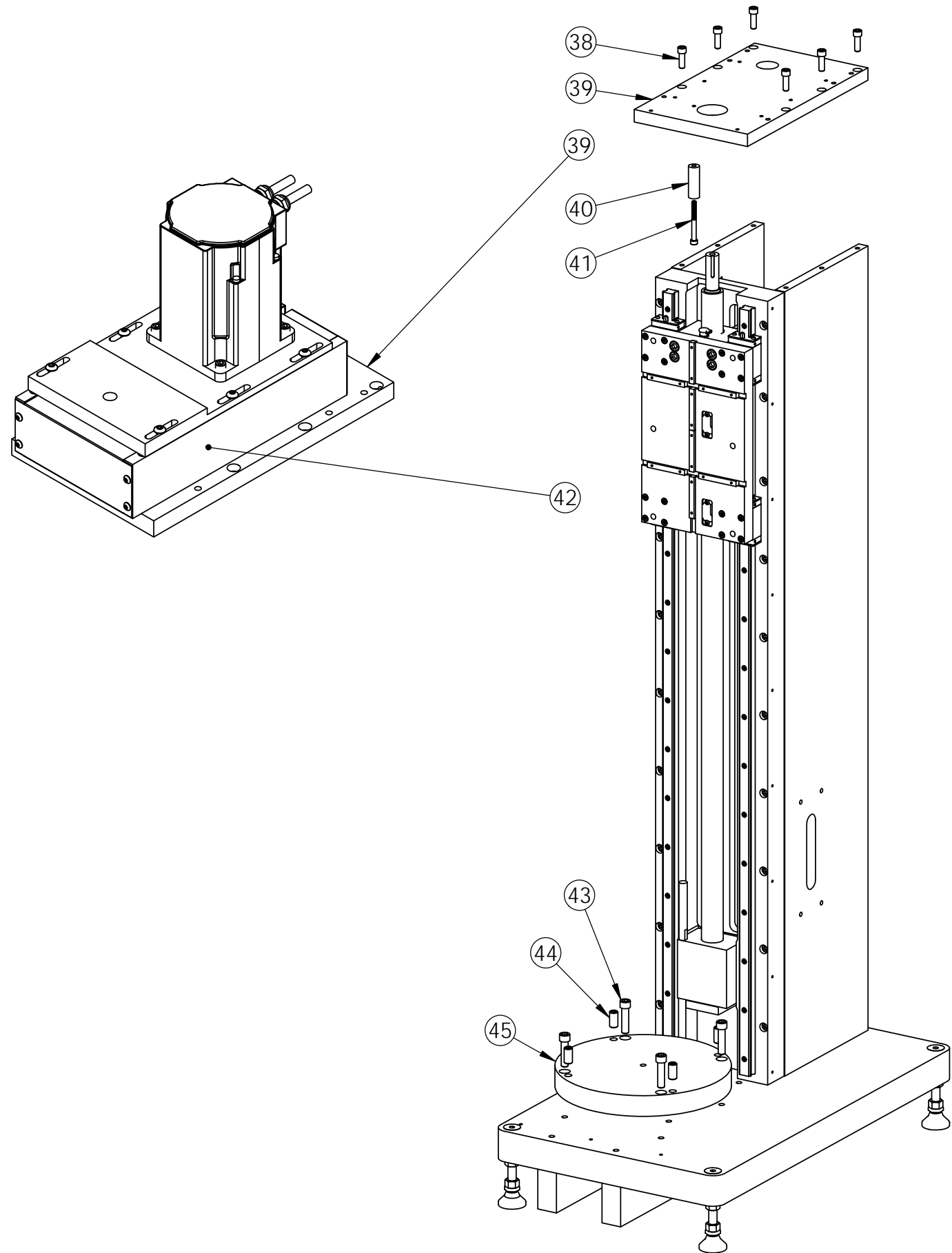

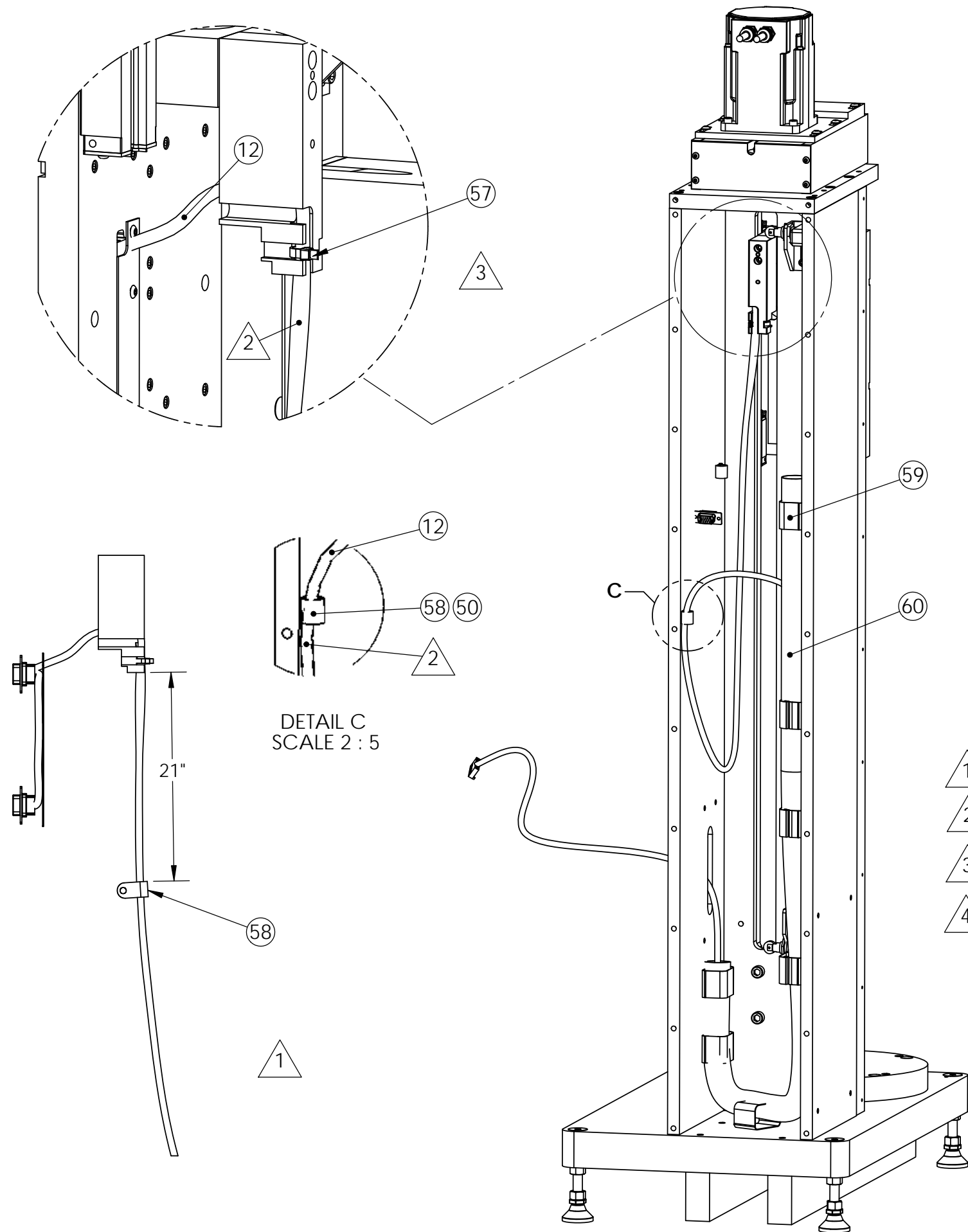

NOTES:

- 1) LOCATE POSITION OF CLAMP, THEN INSTALL CLAMP AS SHOWN.
- 2) ROUTE CABLE #12 AS SHOWN, FASTEN BOTH CABLE CLAMPS AS THE CABLE REQUIRES A DOWN DIRECTON.
- 3) ROUTE CABLE AND INSTALL CABLE TIE(#53) AS SHOWN.
- 4) LOCATE #58 1/3 FROM TOP AND BOTTOM OF #59. APPLY GORILLA GLUE (012-2000-0024-00) PER INSTRUCTIONS.
  - 1) FULLY ETCH BOTH CONTACT AREAS OF BOTH PARTS WITH SANDPAPER
  - 2) CLEAN SURFACES AND REMOVE ALL DUST
  - 3) LIGHTLY DAMP ONE SURACE WITH WATER, DO NOT SATURATE THE SURFCE.
  - 4) EVENLY APPLY GLUE THE OTHER DRY SURFACE ONLY THEN PLACE TOGETHER.
  - 5) RETRACT PLEAT AND APPLY CLAMP TIGHTLY FOR MIN. OF 2 HOURS. DISTRIBUTE EVEN PRESSURE ACROSS ENTIRE SURFACE. FOR BEST RESULTS, LEAVE OVERNIGHT.
  - 6) AFTER UNCLAMPING, CLEAN AND REMOVE ANY UNCURED OR SQUEEZED OUT GLUE, OR WET GLUE. USE A DRY CLOTH, OR INCLUDED STADARD PAINT THINNER.
  - 7) STORE BOTTLE, SQUEEZE OUT THE AIR AND SEAL CAP TIGHTLY.

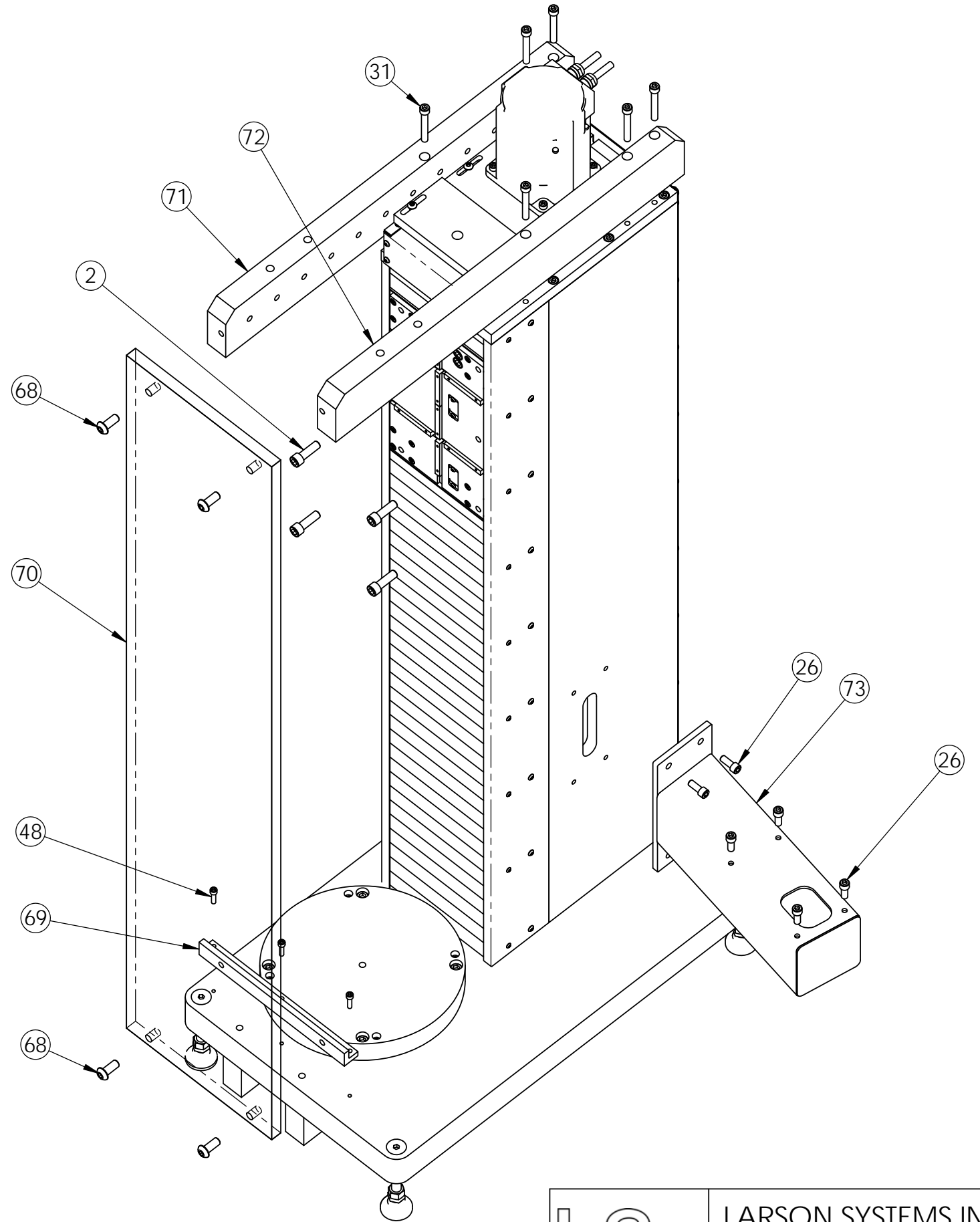
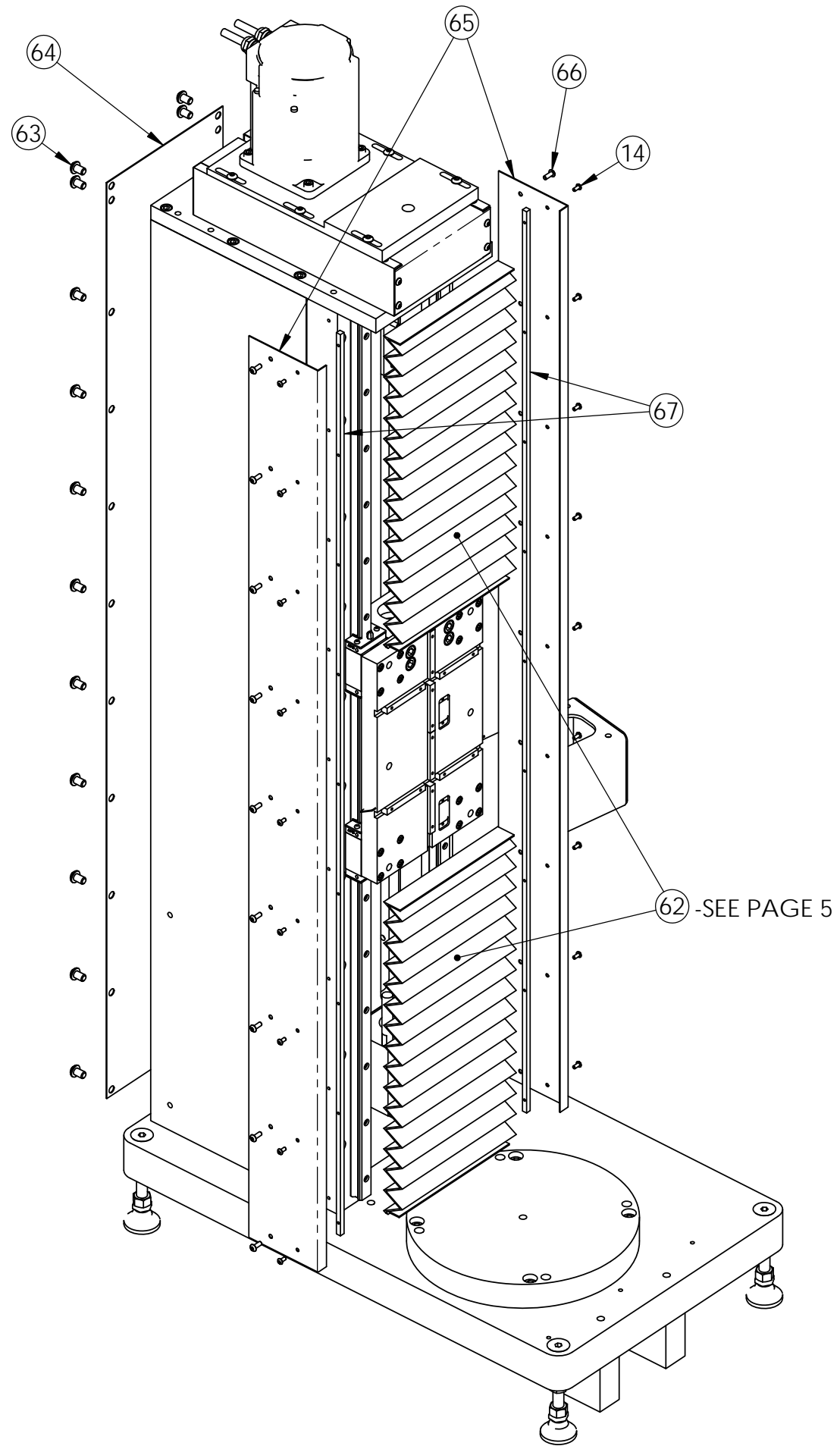



**025-0000-0422-00 N**  
**STAR 25, Stand Alone Assembly**

# Parts List

Rev	By	Date	Description
J	SGS	09-10-2008	Drive Motor Option Created,Removed# 37,38,39,40,41,57,58,59,60,61,62,63,64,65,66,67,73,82 for #90. #47 was 013 0000 0077 00
K	MEL	06-24-2010	Changed item 17 to 025-1000-0603-01, Added 025-1000-0633-02 and 025-1000-0628-01, Added 060-4000-0226-00, 013 0000 0083 00 was 14 is 12 013 0000 0032 00 was 12 is 6 018 0000 1046 02 was 01 013 0000 0406 00 was
M	RRS	03-23-2012	Removed Scale (52 & 53) updated balloons.
N	RRS	09-06-2012	Change item 71 (18-0-1953-00) to 018-0000-1958-00 & -01, Renumbered 72 to 73, changed #41 was 013-0000-0496 00 is 013 0000 0071 00

Item	Qty	Part Number	Rev	Part Name	PCB Location	Part Length
1	8	018-0000-1907-00		STAR 1/4" Square Load cell Key		in.
2	12	013-0000-0083-00		5/16-18 X 1 SHCS		in.
3	16	013-0000-0224-00		M4 X 20 mm SHCS		in.
4	1	018-0000-1908-00	H	STAR Load Cell Mounting Plate		in.
5	4	013-2000-0067-01		Linear Bearing Block With 4 Hole Mount & Higher		in.
6	16	013-0000-0270-00		4-40 X 5/8 SHCS		in.
7	1	013-1000-0025-00		Cup Style Oil Hole Cover		in.
8	1	018-0000-1842-00	F	Connection Plate, STAR		in.
9	1	018-0000-1847-00	F	Scale Connector, STAR		in.
10	2	013-0000-0537-00		8-32 x 1 3/8 SHCS		in.
11	1	018-0000-1930-00	G	Star 25 Mounting Plate		in.
12	Ref	025-1000-0603-01	A	Internal Loadcell Cable, FLASH / STAR 24 -		in.
13	1	018-0000-2469-00	C	Analog Cable Cover		in.
14	26	013-0000-0020-00		4-40 X 1/4 BHCS		in.
15	1	018-0000-2405-01	B	STAR Ballscrew, Hiwin Mods. 24 STROKE		in.
16	1	018-0000-2041-01	F	Star Lower Stop		in.
17	1	013-0000-0298-00		1/4-20 X 5/8 SSS		in.
18	32	013-0000-0188-00		M3-0.5 X 16 mm SHCS		in.
19	1	018-0000-1835-00	J	STAR, Bearing Block		in.
20	2	013-2000-0214-00		24" Linear Bearing Rail (15x940 mm)(STAR)		in.
21	4	013-2000-0090-00	B	Angular Contact Bearing		in.
22	1	018-0000-1846-00		Dust Cover, STAR		in.
23	1	013-2000-0105-00		Lock Washer		in.
24	1	013-2000-0104-00		Lock Nut		in.
25	1	018-0000-1837-00	C	Bearing Clamp, STAR		in.
26	12	013-0000-0198-00		1/4-20 X 5/8 SHCS		in.
27	1	018-0000-1931-00	E	Right Side Plate STAR 24		in.
28	1	018-0000-1932-00	H	Left Side Plate STAR 24		in.
29	1	018-0000-1878-00	F	Base Plate, General STAR		in.
30	14	013-0000-0076-00		5/16-18 X 2 SHCS		in.

Approved by: 

Date: April 17, 2013

**SEE ATTACHED 5 DRAWINGS**





**025-0000-0422-00 N**  
**STAR 25, Stand Alone Assembly**

# Parts List

Rev	By	Date	Description
J	SGS	09-10-2008	Drive Motor Option Created,Removed# 37,38,39,40,41,57,58,59,60,61,62,63,64,65,66,67,73,82 for #90. #47 was 013-0000-0077-00
K	MEL	06-24-2010	Changed item 17 to 025-1000-0603-01, Added 025-1000-0633-02 and 025-1000-0628-01, Added 060-4000-0226-00, 013-0000-0083-00 was 14 is 12, 013-0000-0032-00 was 12 is 6, 018-0000-1946-02 was 01, 013-0000-0406-00 was
M	RRS	03-23-2012	Removed Scale (52 & 53) updated balloons.
N	RRS	09-06-2012	Change item 71 (18-0-1953-00) to 018-0000-1958-00 & -01, Renumbered 72 to 73, changed #41 was 013-0000-0496-00 is 013-0000-0071-00

Item	Qty	Part Number	Rev	Part Name	PCB Location	Part Length
31	12	013-0000-0099-00		1/4-20 X 1 3/4 SHCS		in.
32	4	013-2000-0207-00		Leveling Feet		in.
33	2	013-0000-0179-00		5/16-18 X 3 1/2 SHCS		in.
34	2	018-0000-1876-00	B	Support Beam, STAR 11/24		in.
35	8	013-0000-0238-00		3/8-16 Finished Hex Nut, Zinc		in.
36	4	013-0000-0358-00		3/8-16 X 3 1/4 Flat SHCS Fully Threaded		in.
37	20	013-0000-0061-00		1/4-20 X 1 1/2 SHCS		in.
38	6	013-0000-0032-00		1/4-20 X 3/4 SHCS		in.
39	1	018-0000-1833-00	S	STAR top Plate		in.
40	1	018-0000-1946-02	J	STAR Upper Stop, 1.500" Star 25		in.
41	1	013-0000-0071-00		10-24 X 1 1/4 SHCS		in.
42	Opt	025-0000-0419-03	F	Standard Capacity 1000 lb Drive, STAR / RoboSTAR		in.
42	Opt	025-0000-0419-00	F	High Capacity 2000 lb Drive, STAR / RoboSTAR 240		in.
42	Opt	025-0000-0419-02	F	High Capacity Force, 3000 lb, STAR / RoboSTAR 240		in.
43	4	013-0000-0154-00		5/16-18 X 1 1/4 SHCS		in.
44	4	013-0000-0297-00		3/8-24 X 3/4 SSS, FLAT PT		in.
45	1	018-0000-1874-00		Lower Platform		in.
46	2	013-0000-0010-00		4-40 X 3/8 SHCS		in.
47	Ref	005-2000-0008-00		Resistor - 10 ohm 50w		in.
48	5	013-0000-0161-00		8-32 X 5/8 SHCS		in.
49	1	011-3000-0018-00		S200 SERVO Motor Drive, 3 amp Limit		in.
51	1	018-0000-3101-00	A	Limit Switch Mounting Bracket, Top		in.
52	5	013-0000-0058-00		8-32 X 3/8 SHCS		in.
53	ref	007-0000-0046-00		Cross Roller Plunger, Limit Switch		in.
53	1	025-1000-0628-01	B	Upper Limit Switch Assembly - STAR 25		in.
54	Ref	013-0000-0106-00		8-32 X 1 SHCS		in.
55	1	018-0000-3101-01	A	Limit Switch Mounting Bracket, Bottom		in.
56	1	025-1000-0633-02	A	Lower Limit Switch Assembly, STAR 24		in.
56	Ref	060-4000-0226-00		Procedure : Travel Limit Switch setup for STAR tester		in.
57	1	013-4000-0001-00		Cable Tie - 3 7/8" long		in.

Approved by: 

Date: April 17, 2013

**SEE ATTACHED 5 DRAWINGS**



**025-0000-0422-00 N**  
**STAR 25, Stand Alone Assembly**

# Parts List

Rev	By	Date	Description
J	SGS	09-10-2008	Drive Motor Option Created,Removed# 37,38,39,40,41,57,58,59,60,61,62,63,64,65,66,67,73,82 for #90. #47 was 013 0000 0077 00
K	MEL	06-24-2010	Changed item 17 to 025-1000-0603-01, Added 025-1000-0633-02 and 025-1000-0628-01, Added 060-4000-0226-00, 013 0000 0083 00 was 14 is 12 013 0000 0032 00 was 12 is 6 018 0000 1046 02 was 01 013 0000 0406 00 was
M	RRS	03-23-2012	Removed Scale (52 & 53) updated balloons.
N	RRS	09-06-2012	Change item 71 (18-0-1953-00) to 018-0000-1958-00 & -01, Renumbered 72 to 73, changed #41 was 013-0000-0496 00 is 013 0000 0071 00

Item	Qty	Part Number	Rev	Part Name	PCB Location	Part Length
58	1	013-3000-0017-00		Cable Clamp, 3/8 Dia.		in.
59	7	013-4000-0004-00		Cable Holder		in.
60	1	010-3000-0032-00		Polyethylene Sleeving 1" ID, 5' Length, Black		in.
61	4	018-0000-3069-00		Pleat Doubler Support		in.
62	2	013-7000-0015-00		Star 24 Pleat W/velcro		in.
63	22	013-0000-0128-00		1/4-20 X 3/8 BHSCS		in.
64	1	018-0000-1933-00	B	Back Cover - STAR 24		in.
65	2	018-0000-1944-00	B	STAR 25 Side Cover		in.
66	18	013-0000-0045-00		6-32 X 3/8 BHSCS		in.
67	2	018-0000-1945-00		STAR 24 Pleat Guide		in.
68	4	013-0000-0114-00		5/16-18 X 3/4 BHSCS		in.
69	1	018-0000-1867-00	A	Angle Clamp, Star Shield		in.
70	1	018-0000-1873-01	B	Shield, STAR 24		in.
71	1	018-0000-1958-00	A	Bridge Mount		in.
72	1	018-0000-1958-01	A	Bridge Mount		in.
73	1	018-0000-1879-04	B	Support Arm Weldment		in.

Approved by:

Date:

April 17, 2013

**SEE ATTACHED 5 DRAWINGS**

Printed on 04-17-2013, 4:05:51 PM by DAL

Page 8 of 8

REV	DATE	DESCRIPTION	DRW	APP
		SEE SHEET 4		

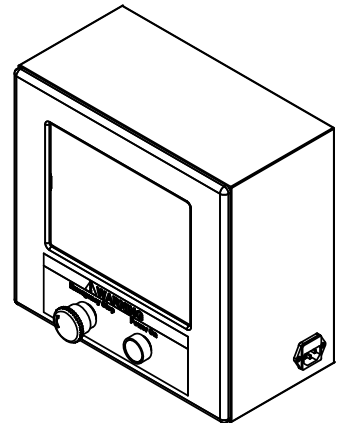
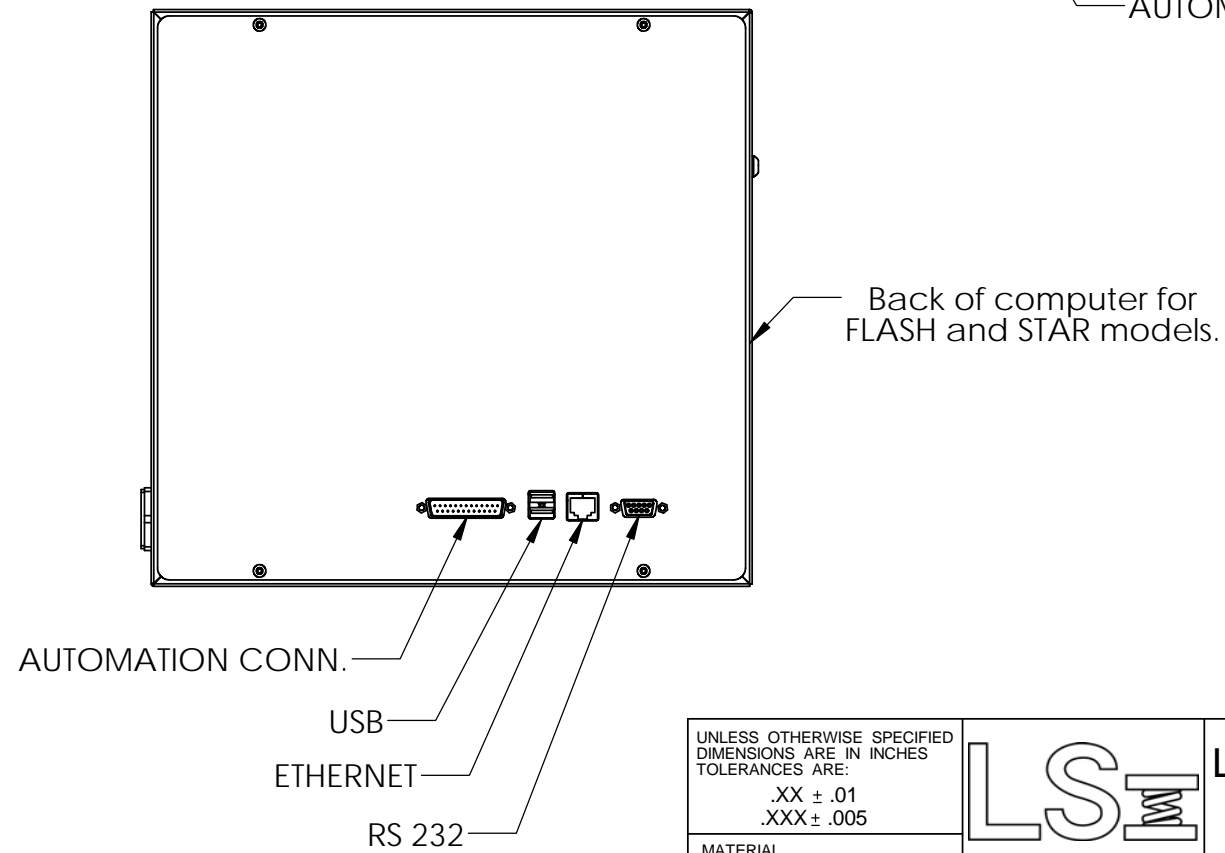
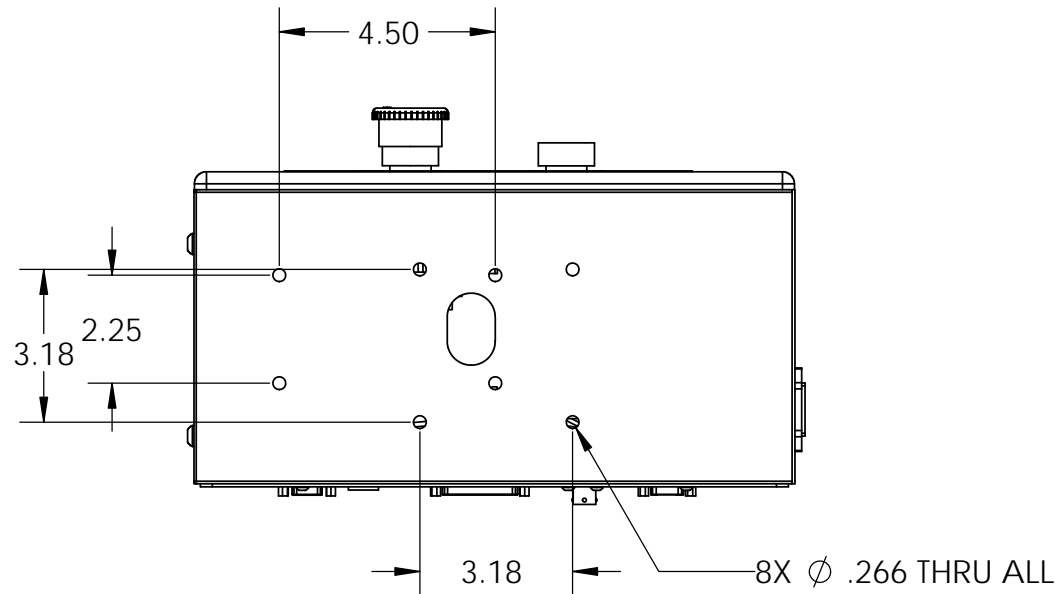
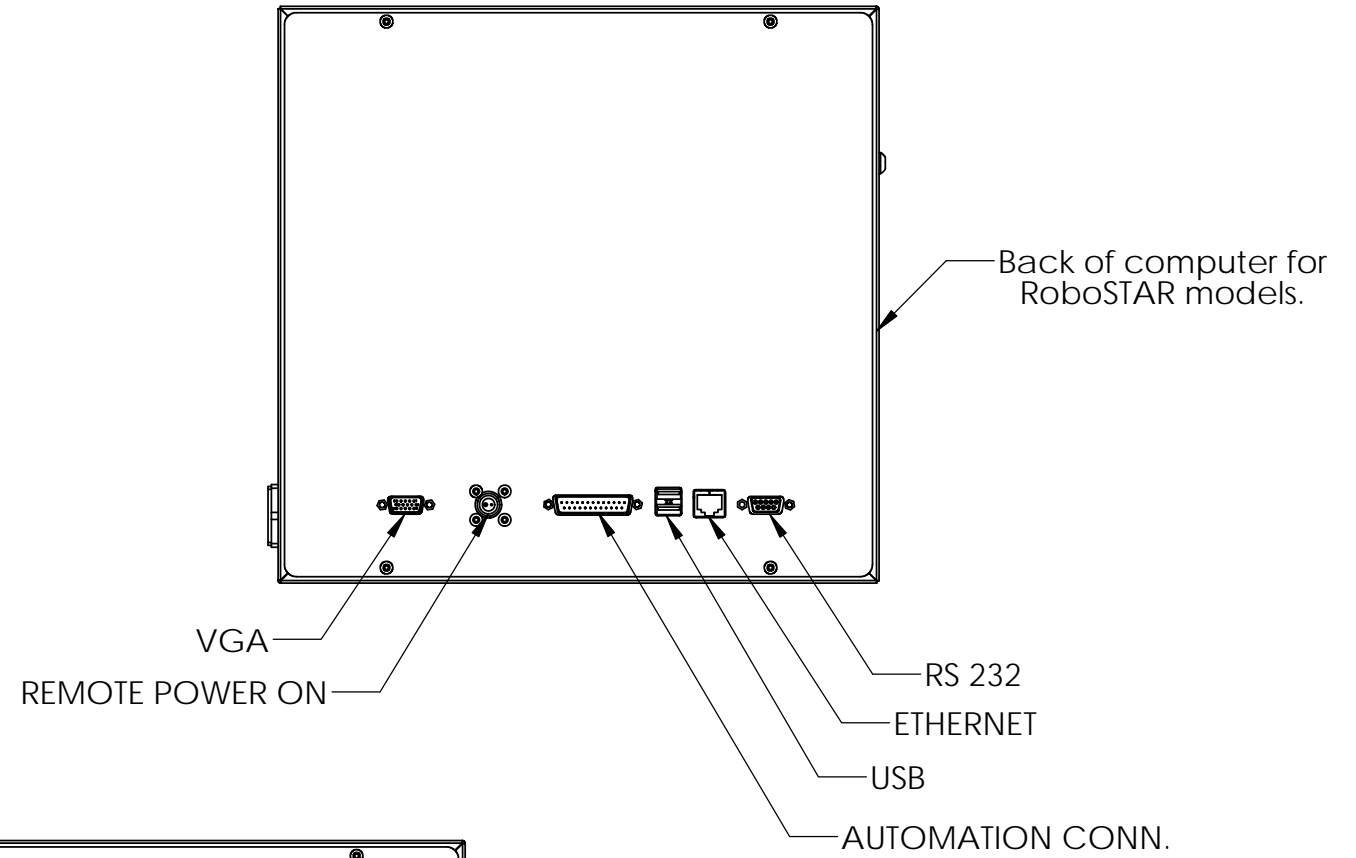
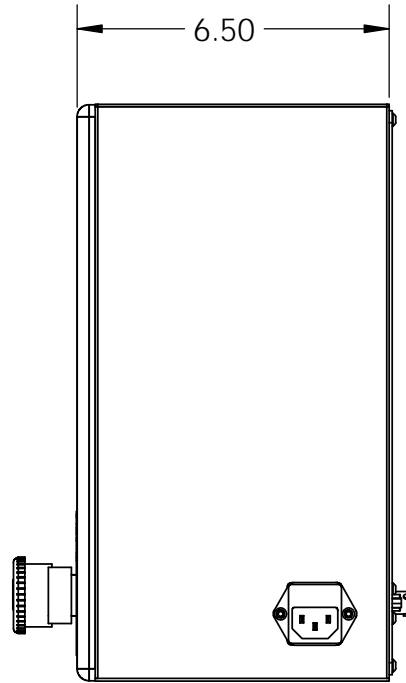
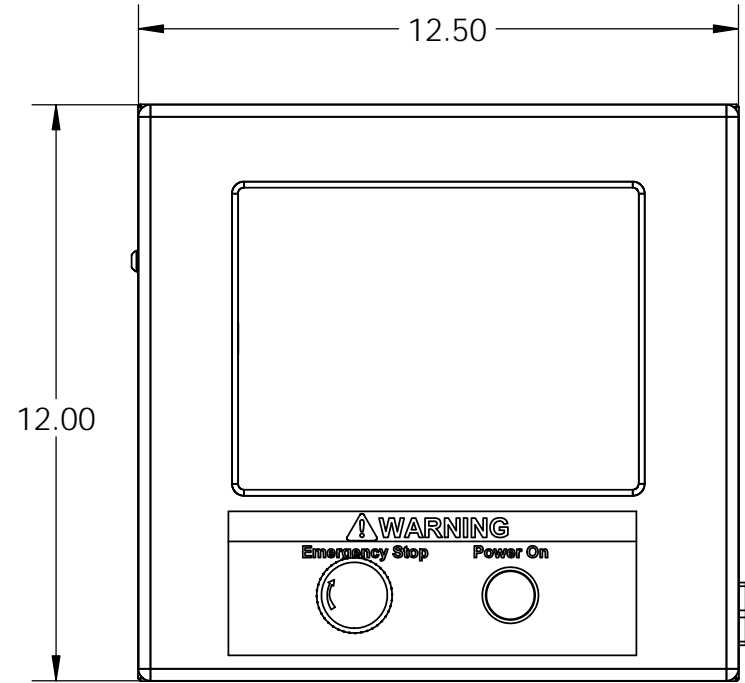

UNLESS OTHERWISE SPECIFIED DIMENSIONS ARE IN INCHES TOLERANCES ARE: .XX ± .01 .XXX ± .005			LARSON SYSTEMS INC.	
			10073 Baltimore St. NE PH. 763-780-2131 Mpls., MN 55449 FAX. 763-780-2182	
MATERIAL See Parts List	APPROVALS	DATE	FLASH COMPUTER ASSEMBLY	
FINISH -	DRAWN KMP	7-6-06	B DWG. NO. 025-0000-0431-10C	
HEAT TREAT	APP.		SCALE: NONE SHEET 1 OF 5	

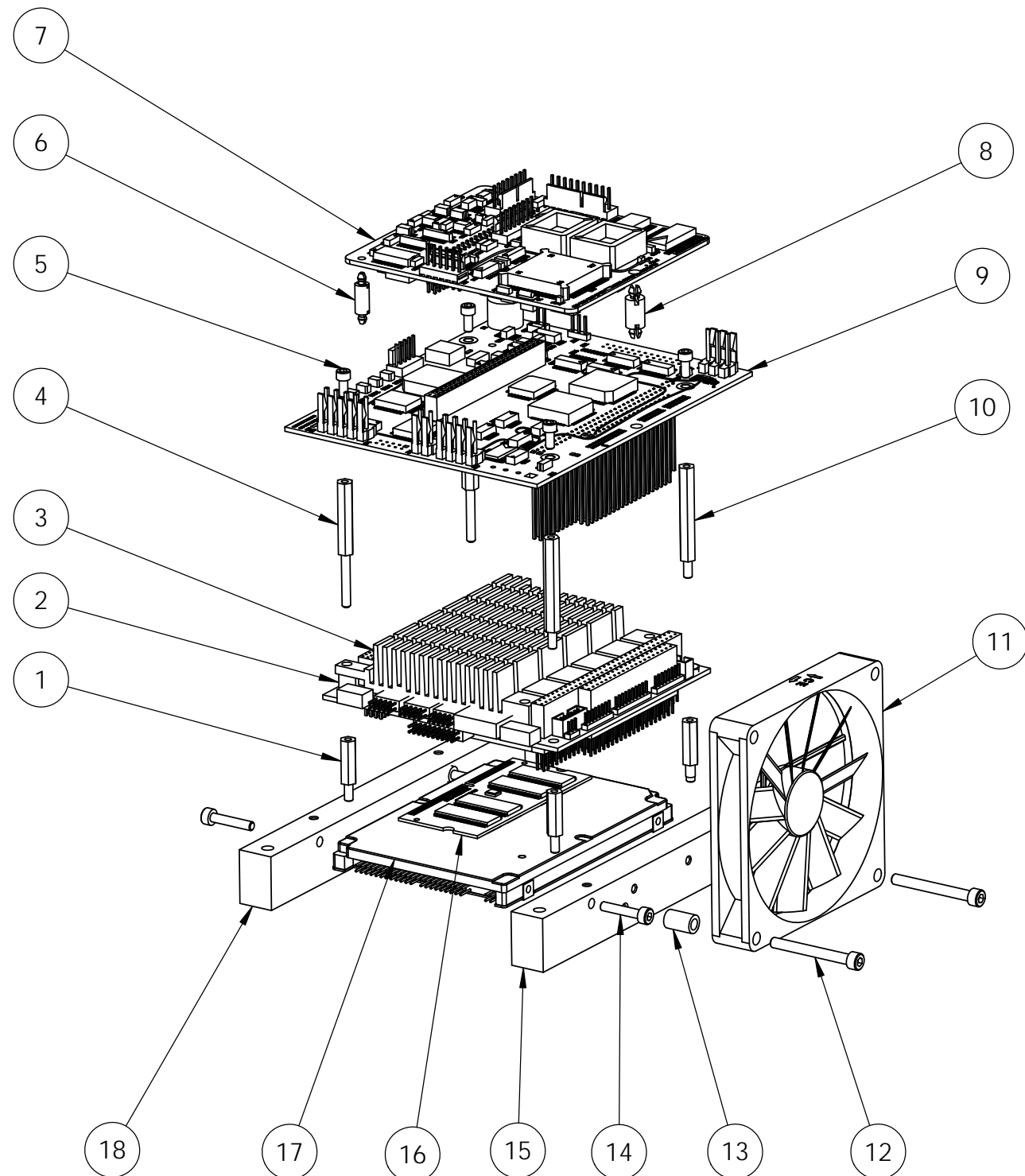

- NOTES:
1. NOTE ORIENTATION OF ITEMS 14, 15, & 18
  2. INSTALL ITEM 16 TO ITEM 3 BEFORE ATTACHING TO ITEM 1
  3. NOTE ORIENTATION OF ITEM 3
  4. PLUG IN CABLES TO ITEM 3 (PC 104 MODULE) PER SCHEMATIC 025-2000-0165-XX
  5. NOTE ORIENTATION OF ITEMS 7 & 9
  6. INSTALL ITEMS 6, 7, 8, & 9 BEFORE ATTACHING TO ITEM 3
  7. NOTE ORIENTATION OF ARROW ON ITEM 11 TO BE POINTING TOWARD ASSEMBLY BEFORE MOUNTING TO ITEM 15.

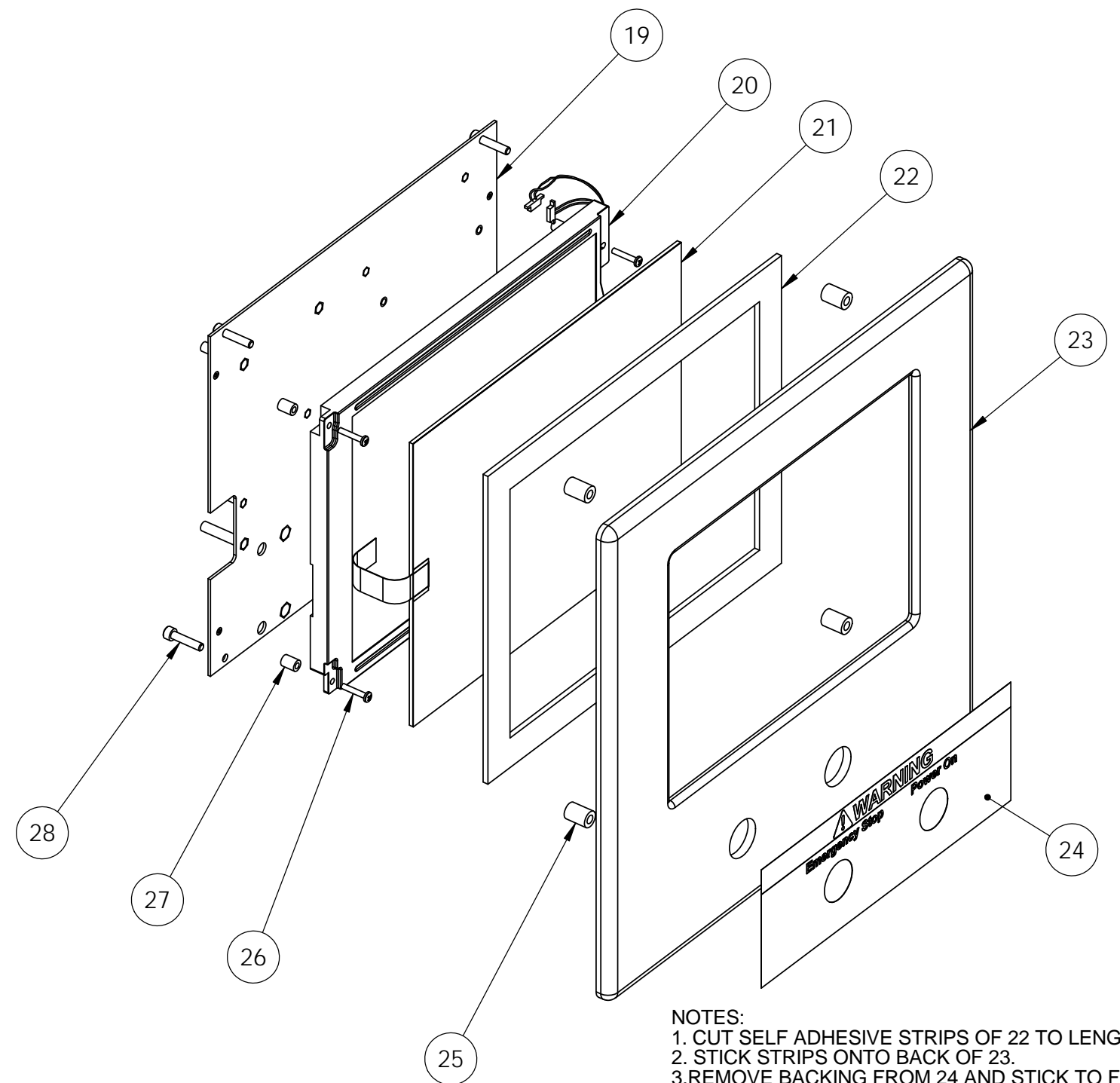

- NOTES:
1. CUT SELF ADHESIVE STRIPS OF 22 TO LENGTH.
  2. STICK STRIPS ONTO BACK OF 23.
  3. REMOVE BACKING FROM 24 AND STICK TO FRONT OF 23.
  4. NOTE ORIENTATION OF ITEMS 19 & 20
  5. INSTALL ITEM 19 TO 20 USING ITEM 26 (4X) & ITEM 27 (4X) BEFORE ATTACHING TO ITEM 23.
  6. NOTE ORIENTATION OF ITEMS 21 & 23
  7. ALIGN ITEM 21 & 23 SO THAT THE ACTIVE AREA OF TOUCHSCREEN IS CENTERED ON THE OPEN AREA OF ITEM 23 (FRONT BEZEL). PEEL & PREPARE FRONT AND BACK ADHESIVE OF TOUCHSCREEN AND PLACE IT.
  8. INSTALL ITEM 19 TO ITEM 23 USING ITEM 25 AND ITEM 28.

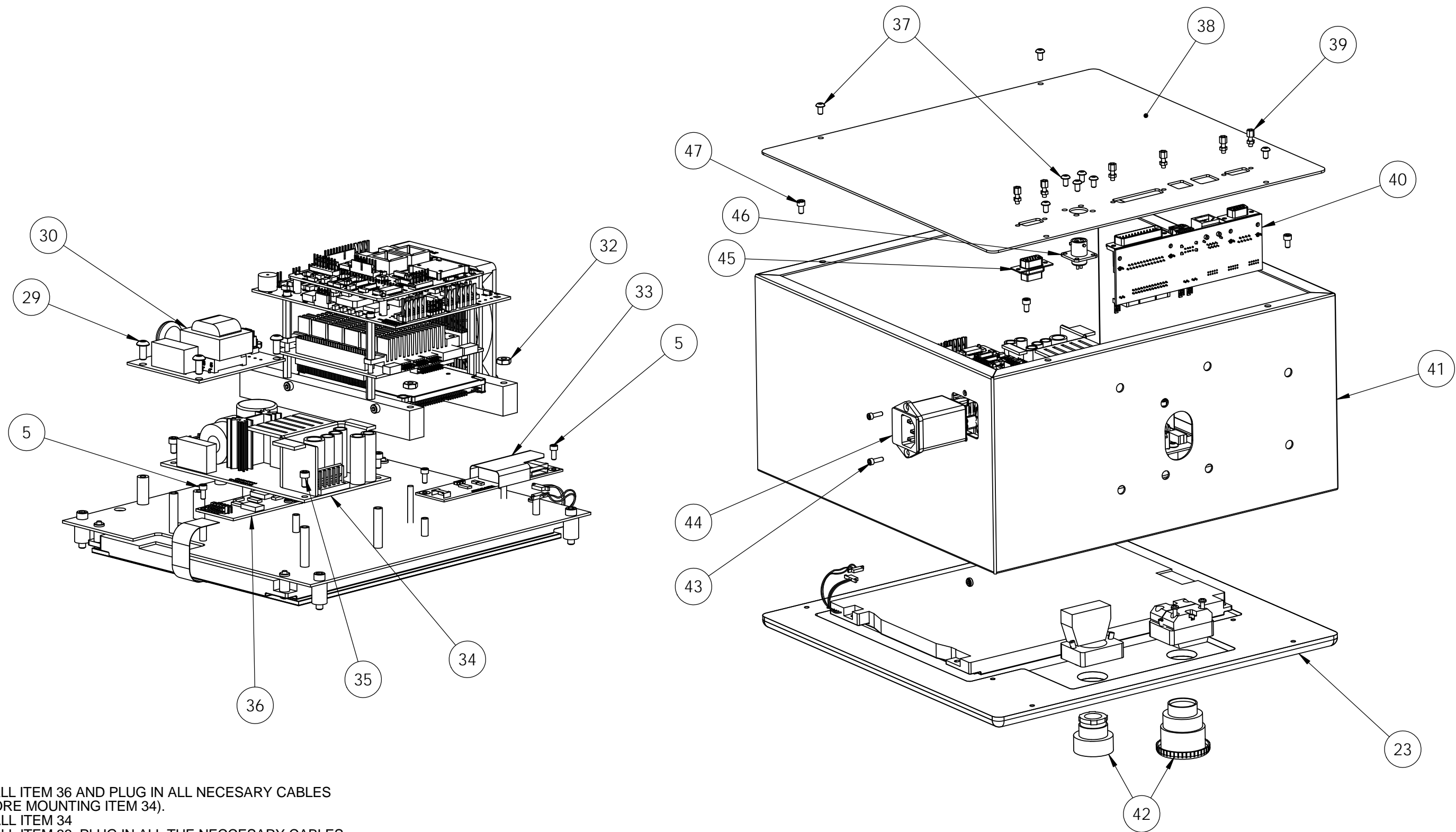

NOTES:

1. INSTALL ITEM 36 AND PLUG IN ALL NECESSARY CABLES (BEFORE MOUNTING ITEM 34).
2. INSTALL ITEM 34
3. INSTALL ITEM 33. PLUG IN ALL THE NECESSARY CABLES
4. PLUG IN ALL CABLES TO ITEM 31 (EXTERNAL CONNECTORS ASSEMBLY) AND ALL REMAINING CABLES PER SCHEMATIC 025-2000-0165-XX

**5. HAVE ASSEMBLY CHECKED BEFORE NEXT OPERATION.**

6. APPLY LOCTITE 242 BLUE TO ITEMS 47 AT THE END OF ASSEMBLY.
7. **FOR 230V MODEL**, BOTH JUMPERS FROM ITEM 30 "AC DISTRIBUTION PC ASSEMBLY" NEED TO BE REMOVED AND ONE JUMPER NEEDS TO BE PLACED ON PINS 2 AND 3

NOTES:

1. INSTALL ITEMS 42 TO ITEM 23
2. INSTALL ITEM 41 TO BACK OF BEZEL USING ITEM 35 (4X) BEFORE ATTACHING ITEMS 39 & 40



# 025-0000-0431-10 C

## FLASH - Computer Assembly

# Parts List

Rev	By	Date	Description
	KMP	07-05-2006	
A	DAL	08-03-2007	Added 060-4000-0202-00 factory setup and startup instructions Add Item 21
B	EJS	05-23-2008	REMOVED ITEMS 45, 46. (WAS 25-1-501-02 & 25-1-502-02) REPLACE WITH ITEM 45, THE WHOLE SWITCH ASSEMBLY
C	RRS	03-23-2012	Removed 47, 48 added Robostar config., combined e-stop and on switch into one assembly. renumbered 42 through 47. Removed special notes and added notes concerning location and numbers for the 230V models

Item	Qty	Part Number	Rev	Part Name	PCB Location	Part Length
1	4	018-0000-2479-00	A	4-40 male - female standoff		in.
2	2	018-0000-3205-00		Spacer For Flash PC104 Module		in.
3	1	016-2000-0012-00	B	PC104 (Pentium) for FLASH Systems		in.
4	2	018-0000-2802-00	A	Standoff Hex, 4-40 X 1.00 M-F		in.
5	8	013-0000-0178-00		4-40 X 1/4 SHCS		in.
6	2	018-0000-2680-00	A	Standoff Double Snap-in (.100 Dia Hole)		in.
7	1	025-1000-0299-01	N	SDHT 3 Analog / Digital PCB Assembly - FLASH		in.
8	1	018-0000-2682-00	C	Standoff Double Snap-in (.152 Dia Hole)		in.
9	1	025-1000-0359-01	F	FLASH PC104 Adapter (Pentium)		in.
10	2	018-0000-2801-00	A	Standoff Hex, 4-40 X 1.353 M-F		in.
11	1	025-1000-0413-01	C	Fan Assembly, FLASH (Pentium)		in.
12	2	013-0000-0470-00		6-32 X 1 1/4 SHCS		in.
13	2	018-0000-2672-00		Spacer, .250 Dia, Flash		in.
14	4	013-0000-0188-00		M3-0.5 X 16 mm SHCS		in.
15	1	018-0000-2478-01	C	FLASH PC 104 Module Mounting Bar, Left		in.
16	1	016-2000-0013-00		1GB Kingston 667 MHz DDR2 SODIMM Memory		in.
17	1	016-2000-0006-00	B	2.5" SATA Notebook Hard Drive		in.
18	1	018-0000-2478-00	C	FLASH PC104 Module Mounting Bar, Right		in.
19	1	018-0000-2411-00	G	LCD Mounting Plate		in.
20	1	014-4000-0006-00		LCD for FLASH Systems		in.
21	1	014-4000-0008-00	B	Touchscreen for FLASH Systems		in.
22	4	010-3000-0035-00		3/4" Vinyl Foam Tape		in.
23	1	018-0000-2862-00	A	Computer Front Bezel, Flash		in.
24	1	017-0000-0029-02	B	Emergency Stop / Power On / Warning Label		in.
25	4	018-0000-2674-00		Spacer BEZEL, Flash		in.
26	4	013-0000-0163-00		4-40 X 5/8 PHMSPH		in.
27	4	018-0000-2475-00		.250 x .334 Display Spacer ID .134, Flash		in.
28	4	013-0000-0156-00		8-32 X 3/4 SHCS		in.
29	4	013-0000-0012-00		8-32 X 3/8 Button Head Cap Screw		in.
30	1	025-1000-0583-00		Flash AC Distribution PCB Assembly		in.

Approved by: 

Date: April 26, 2012

**SEE ATTACHED 3 DRAWINGS**

Printed on 04-26-2012, 11:01:55 AM by DAL

Page 4 of 5



**025-0000-0431-10 C**  
**FLASH - Computer Assembly**

# Parts List

Rev	By	Date	Description
	KMP	07-05-2006	
A	DAL	08-03-2007	Added 060-4000-0202-00 factory setup and startup instructions Add Item 21
B	EJS	05-23-2008	REMOVED ITEMS 45, 46. (WAS 25-1-501-02 & 25-1-502-02) REPLACE WITH ITEM 45, THE WHOLE SWITCH ASSEMBLY
C	RRS	03-23-2012	Removed 47, 48 added Robostar config., combined e-stop and on switch into one assembly. renumbered 42 through 47. Removed special notes and added notes concerning location and jumpers for the 230V models

Item	Qty	Part Number	Rev	Part Name	PCB Location	Part Length
32	4	013-0000-0002-00		6-32 Hex Nut		in.
33	1	014-4000-0007-00	A	Backlight Inverter PCB assembly		in.
34	1	011-0000-0022-00	A	5V / 12V DC SUPPLY FOR FLASH		in.
35	4	013-0000-0142-00		6-32 X 1/4 SHCS		in.
36	1	014-4000-0009-00	A	TOUCHSCREEN INTERFACE PCB		in.
37	8	013-0000-0077-00		6-32 X 1/4 BHCS		in.
38	1	018-0000-2864-00	B	Computer Back Cover, FLASH / Star		in.
38	Ref	018-0000-2864-02	B	Computer Back Cover, FLASH / RoboStar, with VGA		in.
39	6	013-1000-0010-00		Female Screw Lock		in.
40	1	025-1000-0393-00	A	FLASH External Connectors Assembly		in.
41	1	018-0000-2863-00		Flash Computer Enclosure		in.
42	1	025-1000-0585-00		Cable, Flash AC Dist pcb to Start/Epo switches		in.
43	2	013-0000-0010-00		4-40 X 3/8 SHCS		in.
44	1	025-1000-0500-00	D	Power Entry 120V Cable, Flash		in.
44	Ref	025-1000-0500-01	D	Power Entry 230V Cable, Flash		in.
45	Ref	025-1000-0641-01		VGA Cable for FLASH Computers - Extended		in.
46	Ref	025-1000-0585-01		Cable, Flash AC Dist pcb to Start/Epo switches &		in.
47	4	013-0000-0139-00		8-32 X 1/4 SHCS		in.
50	Ref	060-4000-0202-00	E	Procedure : FLASH Tester Computer Assembly		in.
51	1	016-2000-0014-00	A	Windows 7 Pro OEM Install DVD		in.

Approved by: 

Date: April 26, 2012

**SEE ATTACHED 3 DRAWINGS**



**Larson Systems Inc.**  
10073 Baltimore Street NE  
Minneapolis, MN 55449-4425  
[www.larsonsystems.com](http://www.larsonsystems.com)

763-780-2131  
1-877-780-2131  
Fax: 763-780-2182  
[info@larsonsystems.com](mailto:info@larsonsystems.com)

