

Larson Systems Inc.

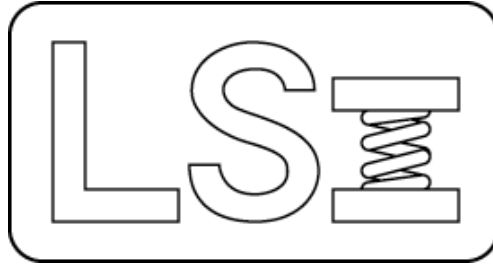

FLASH Lite 24 Parts List

050-0000-0136-00 – 200 lb. Whisper Drive

050-0000-0135-00 – 1,000 lb. Whisper Drive



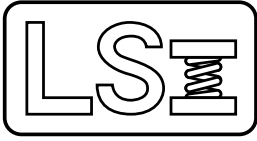

050-0000-0136-00 A
FLASH LITE 24 - 200 lb

Parts List

Rev	By	Date	Description
	DAL	11-11-2006	
A	DAL	07-19-2010	del 018-0000-2477-00, 013-0000-0231-00, added 059-0000-0009-00

Item	Qty	Part Number	Rev	Part Name	PCB Location	Part Length
1	1	025-0000-0174-11		Frame Assembly, 24 200 lb		in.
2	1	025-0000-0342-07	C	Flashlite Computer Assembly		in.
3	1	025-2000-0130-01	A	Electrical Schematic, FLASHLITE 11/24, 200 lb 120 / 240 VAC		in.
4	1	060-1000-0087-00		User Manual - FLASH Lite		in.
5	1	060-2000-0024-01		Parts List - FLASH 24		in.
6	1	025-6000-0029-00	A	Sticker Assembly - FLASH LITE		in.
7	1	059-0000-0009-00	C	Shipping Crate -Flash 24		in.

Approved by:

Date:

July 20, 2010

REV	DATE	DESCRIPTION	DRW	APP
		SEE SHEET 5		

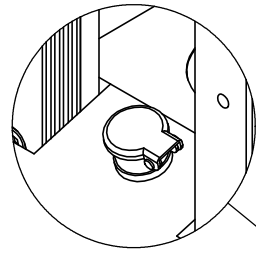

NOTE: 1. ADD OIL TO ITEM 15
AFTER ASSY

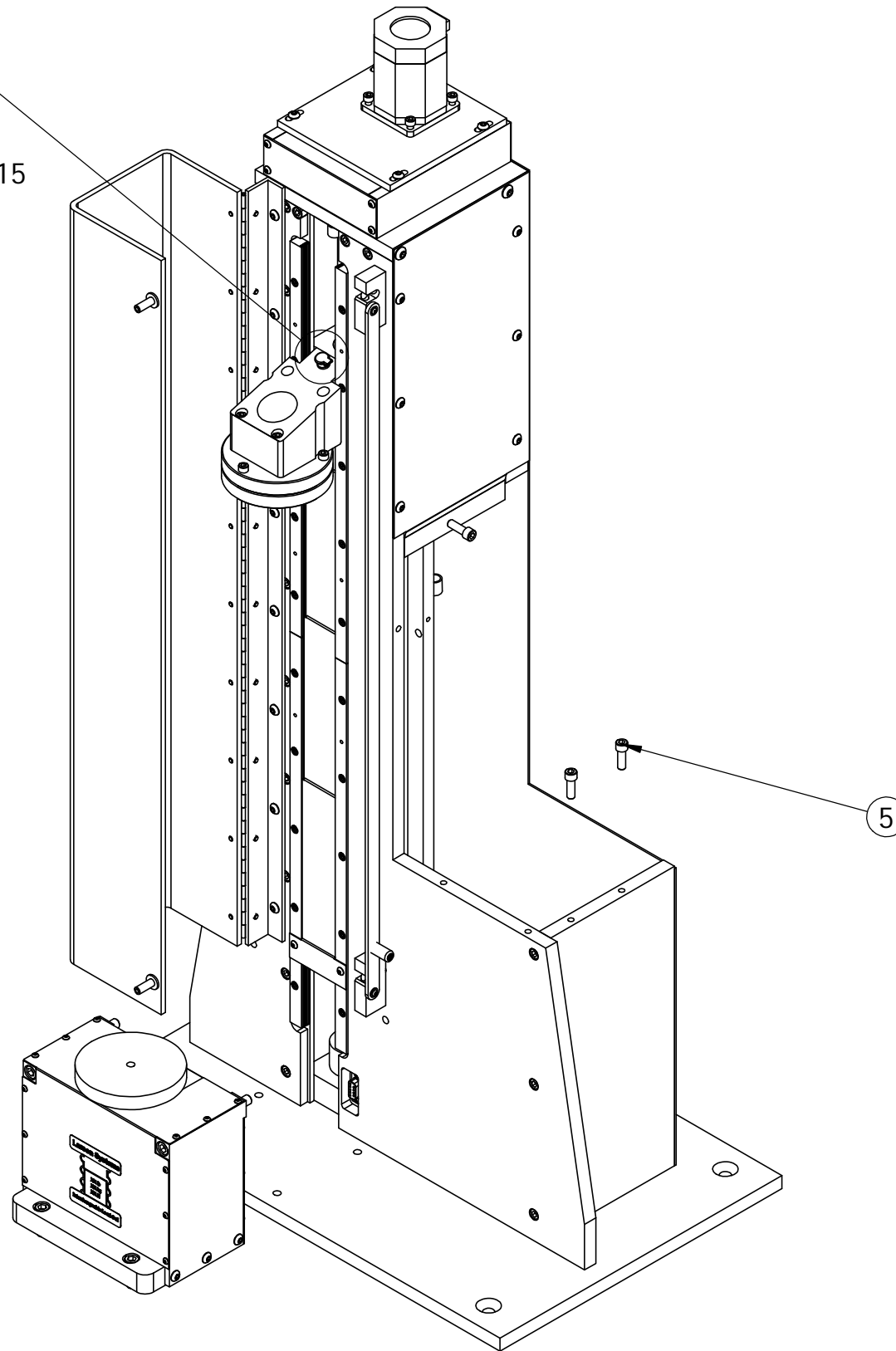

FLASH
REF. ONLY

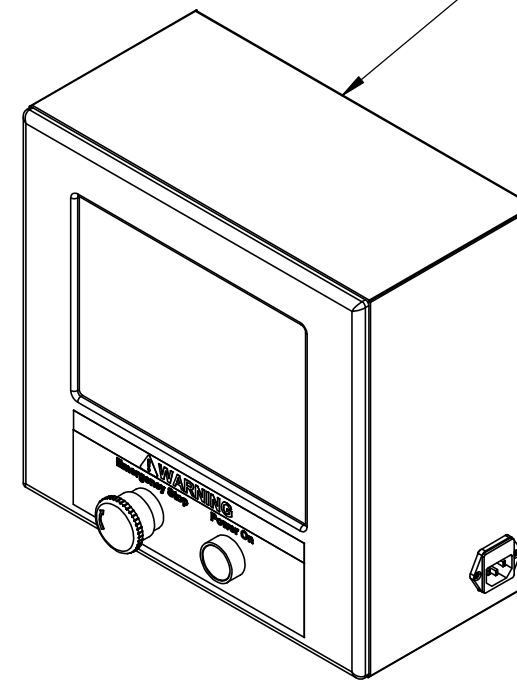

FLASHLITE
REF. ONLY

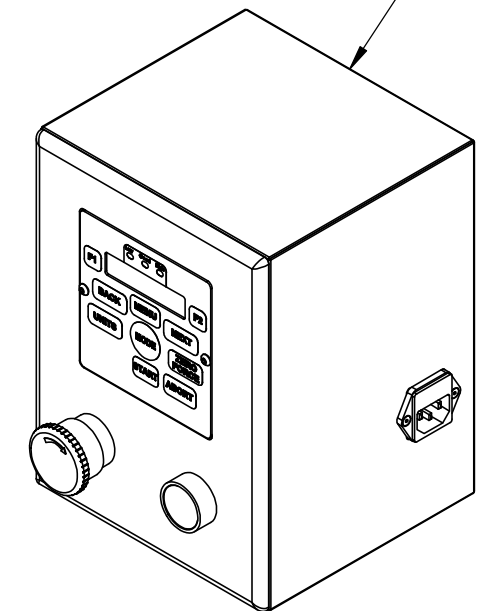

UNLESS OTHERWISE SPECIFIED
DIMENSIONS ARE IN INCHES
TOLERANCES ARE:
.XX ± .01
.XXX ± .005



LARSON SYSTEMS INC.

10073 Baltimore St. NE PH. 763-780-2131
Mpls., MN 55449 FAX. 763-780-2182

MATERIAL	APPROVALS	DATE	FRAME ASSEMBLY 24 200 lb
FINISH	DRAWN MEM	12-03-03	
HEAT TREAT	APP.		B DWG. NO. 025-0000-0174-11
	APP.		SCALE: NONE SHEET 1 OF 7

NOTES:
 1. SQUARE UP ASSEMBLY USING
 FIXTURE & PROCEDURE 060-4000-0035

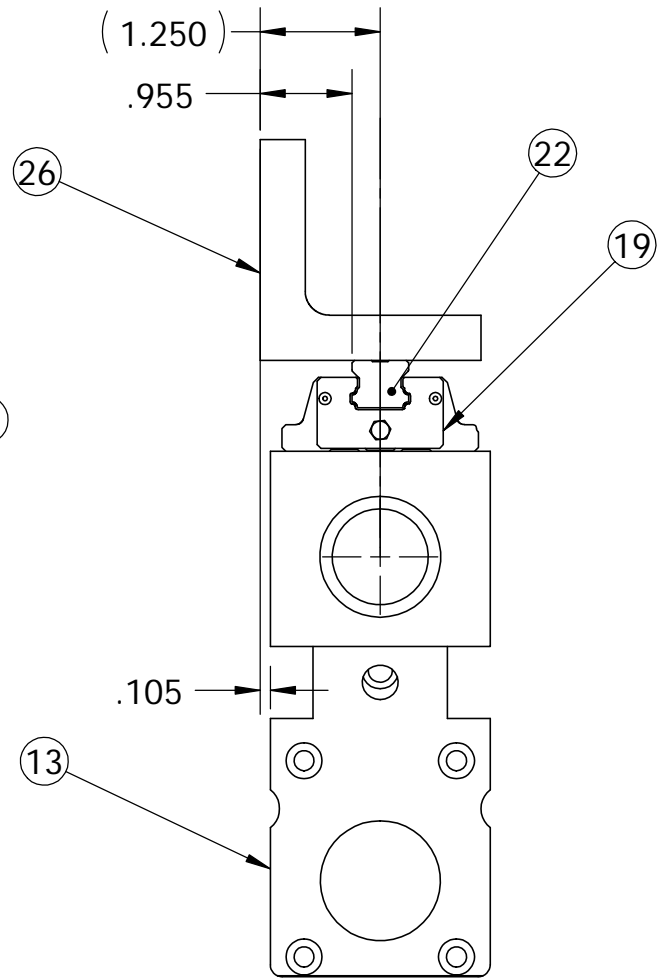
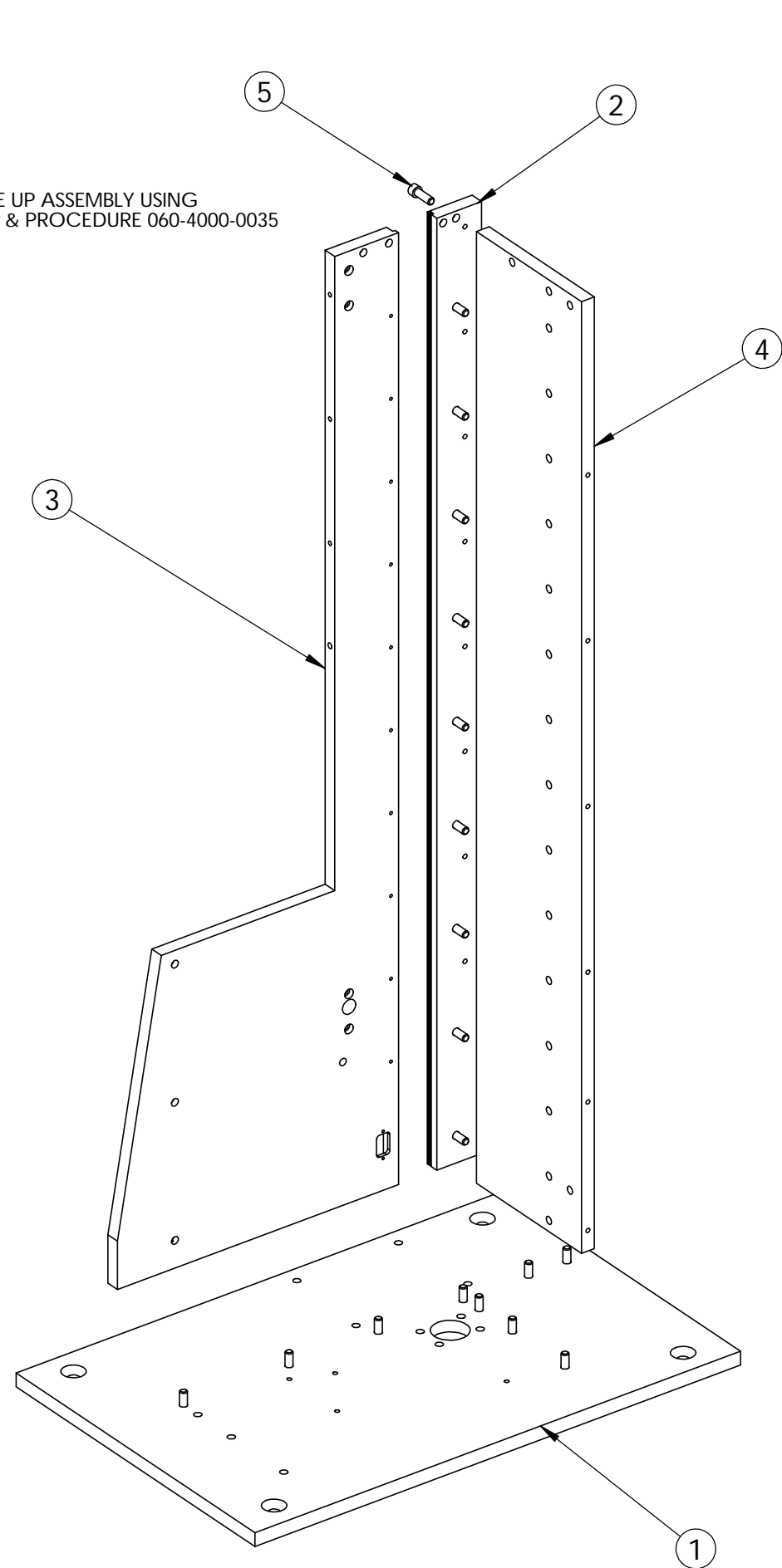

NOTES:
 1. ALIGN ITEMS 13, 22 & 26 TO ACHIEVE
 DIM .955 & .105
 2. GREASE ITEM 8
 3. NOTICE ORIENTATION OF BEARINGS,
 ITEM 8
 4. GREASE SURFACES OF ITEM 7 THEN
 FASTEN ITEM 6, TORQUE 40 FT/LB
 5. TIGHTEN FINGERTIGHT ITEM 9 TO 12
 6. TIGHTEN BALL NUT, ITEM 18 TO 40 FT/LB
 7. NOTICE ORIENTATION OF ITEM 15

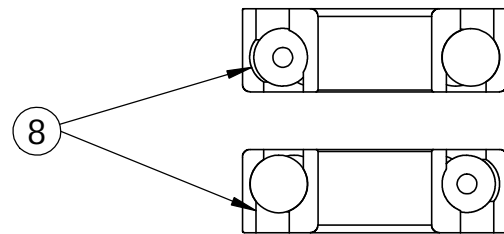

DETAIL

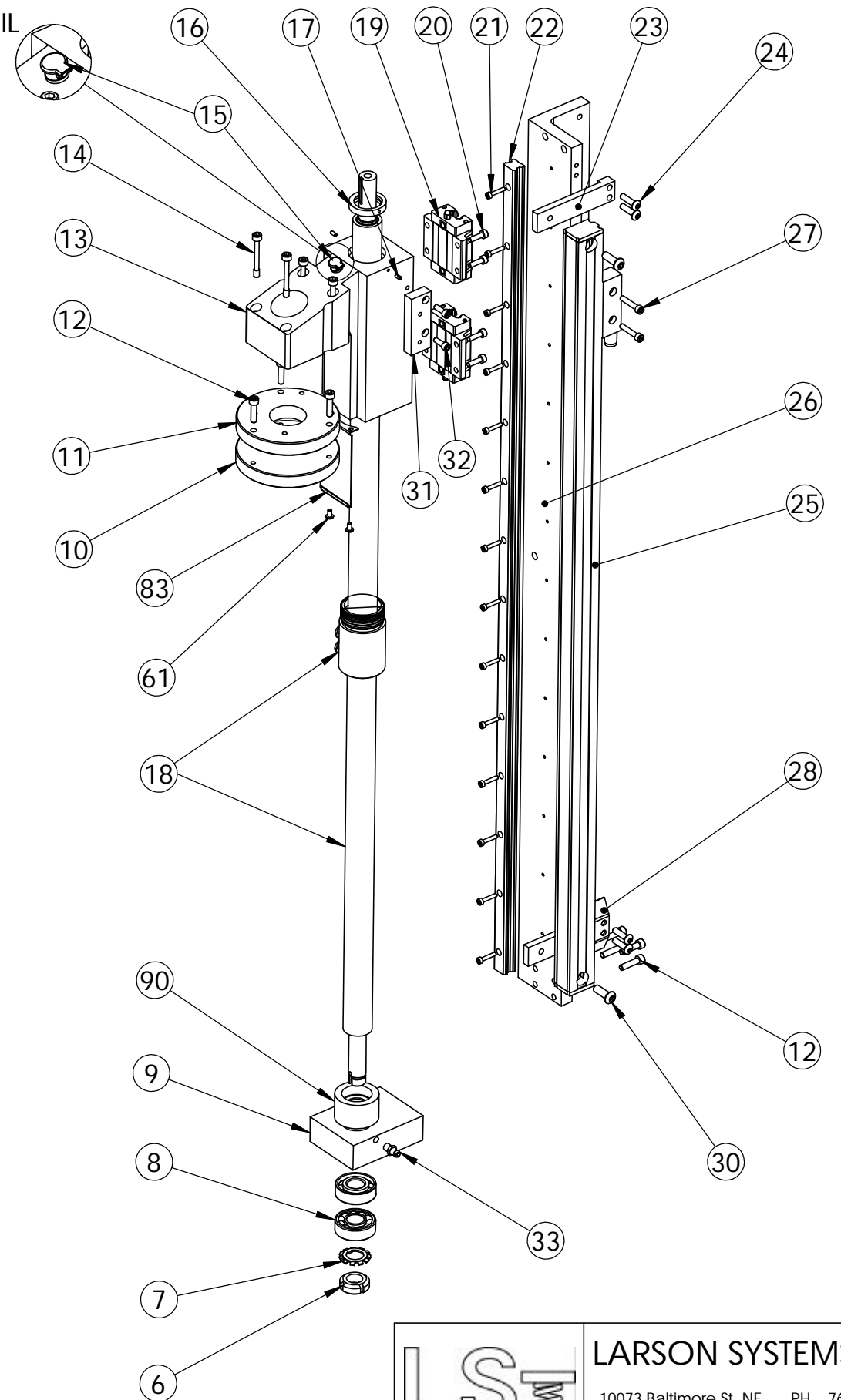

	LARSON SYSTEMS INC.	
	10073 Baltimore St. NE Mpls., MN 55449	PH. 763-780-2131 FAX. 763-780-2182
B SCALE: NONE	DWG. NO. 025-0000-0174-11	SHEET 2 OF 7

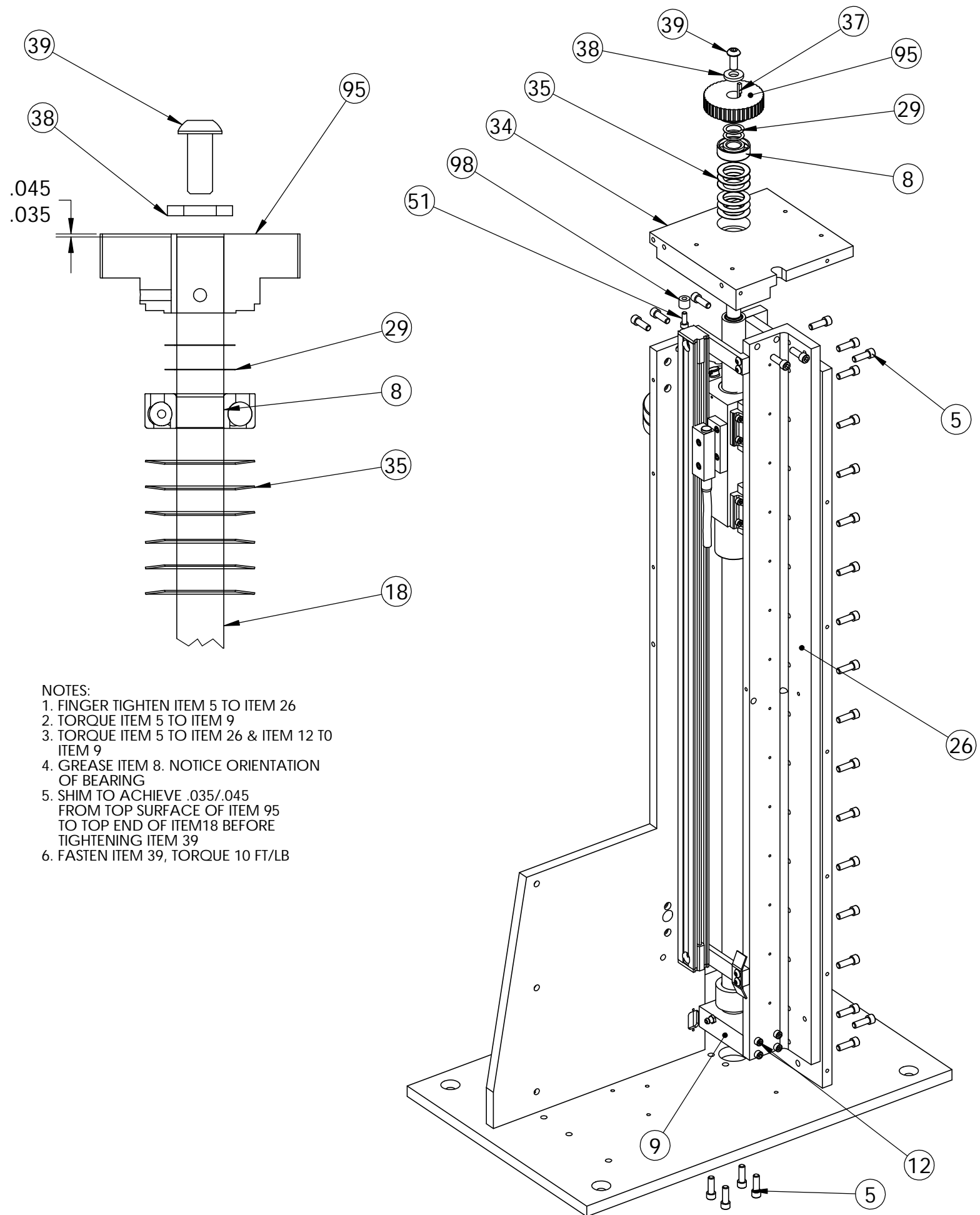

- NOTES:
 1. FINGER TIGHTEN ITEM 5 TO ITEM 26
 2. TORQUE ITEM 5 TO ITEM 9
 3. TORQUE ITEM 5 TO ITEM 26 & ITEM 12 TO ITEM 9
 4. GREASE ITEM 8. NOTICE ORIENTATION OF BEARING
 5. SHIM TO ACHIEVE .035/.045 FROM TOP SURFACE OF ITEM 95 TO TOP END OF ITEM 18 BEFORE TIGHTENING ITEM 39
 6. FASTEN ITEM 39, TORQUE 10 FT/LB

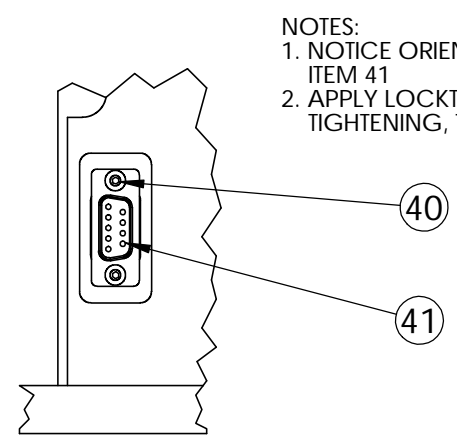

- NOTES:
 1. NOTICE ORIENTATION OF CONNECTOR, ITEM 41
 2. APPLY LOCKTITE 242 TO ITEM 40, TIGHTENING, THEN LOOSEN 1/2 TURN

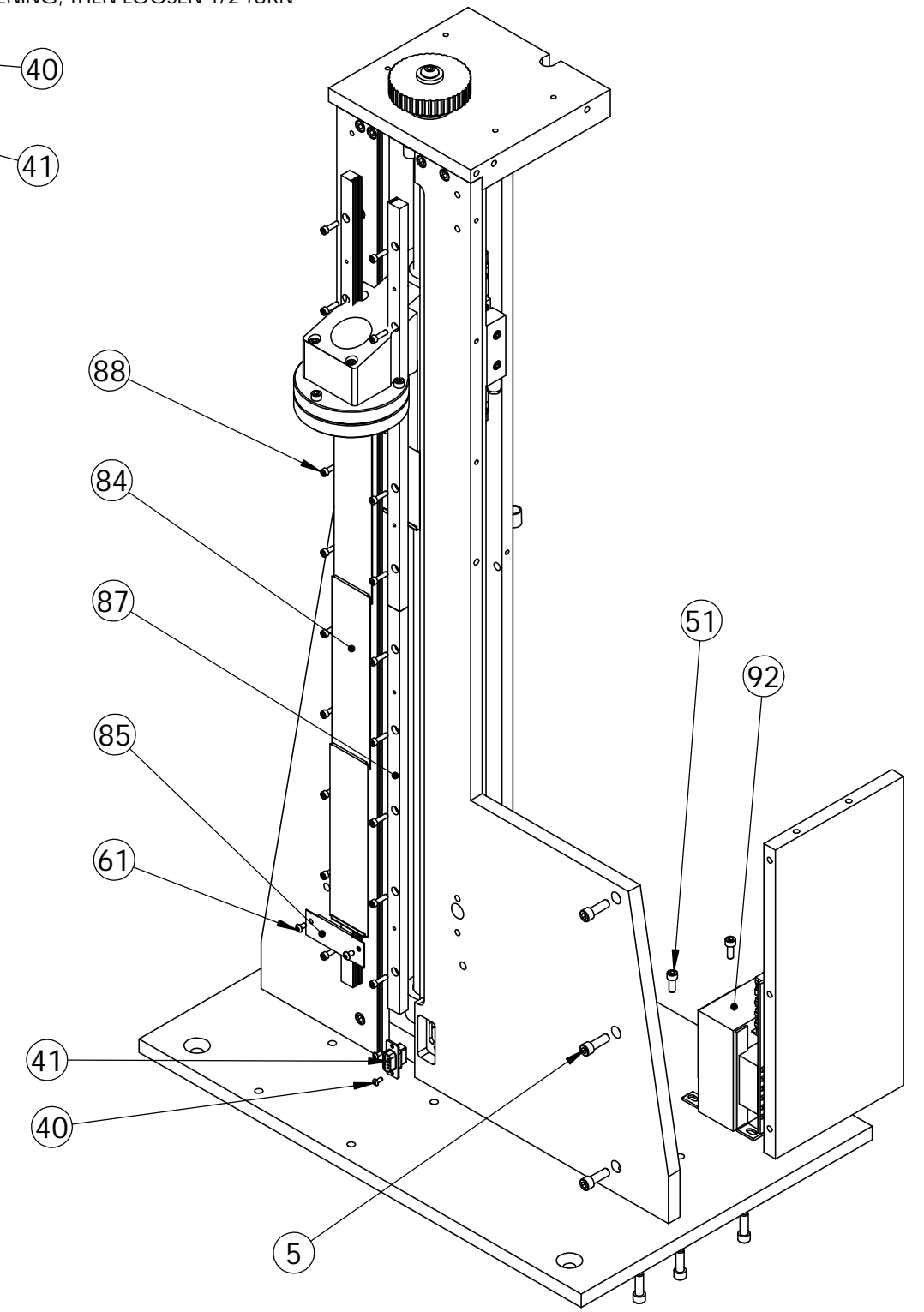

	LARSON SYSTEMS INC.	
	10073 Baltimore St. NE Mpls., MN 55449	PH. 763-780-2131 FAX. 763-780-2182
B SCALE: NONE	DWG. NO. 025-0000-0174-11	SHEET 3 OF 7

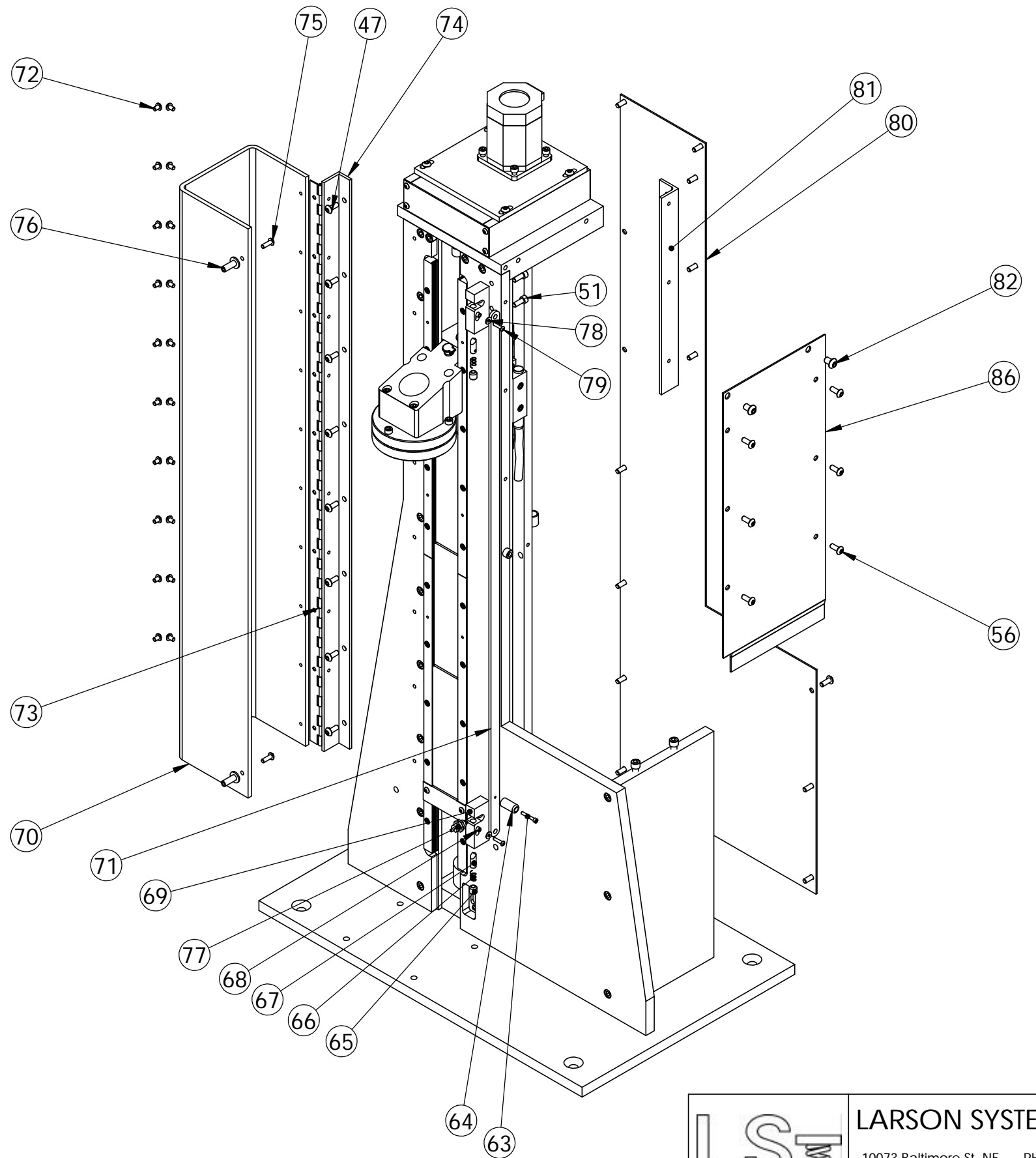
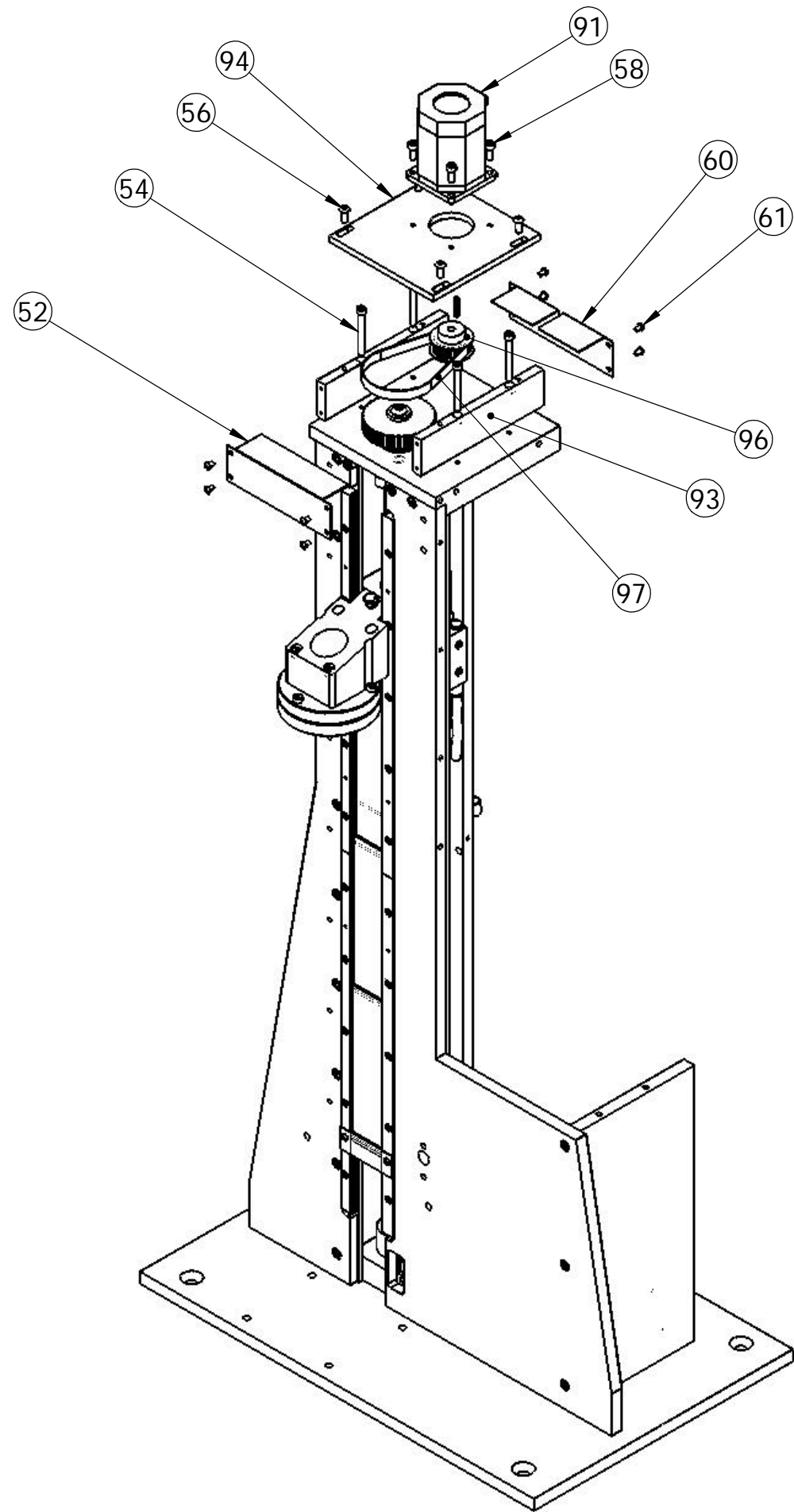

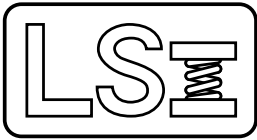

025-0000-0174-11

Frame Assembly, 24 200 lb

Parts List

Rev	By	Date	Description
	KMP	05-08-2007	

Item	Qty	Part Number	Rev	Part Name	PCB Location	Part Length
1	1	018-0000-0176-04	Z	Base Plate		in.
2	1	018-0000-0171-03	G	LEFT SUPPORT, UT24		in.
3	1	018-0000-0339-01	J	Right Support, UT 24		in.
4	1	018-0000-0887-01	E	LEFT BACK SUPPORT, UT24		in.
5	56	013-0000-0032-00		1/4-20 X 3/4 SHCS		in.
6	1	013-2000-0104-00		Lock Nut		in.
7	1	013-2000-0105-00		Lock Washer		in.
8	3	013-2000-0090-00	A	Angular Contact Bearing		in.
9	1	018-0000-2055-00	D	UT Bearing Block		in.
10	1	018-0000-1009-00	E	Upper Platform, 5/16-18		in.
11	1	018-0000-0164-00	M	3.5" Upper Platform		in.
12	7	013-0000-0115-00		10-32 X 3/4 SHCS		in.
13	1	018-0000-2056-00	G	Upper Platform Mount		in.
14	4	018-0000-1732-03	B	10-32 Custom Screws for Platform Alignment		in.
15	1	013-1000-0025-00		CUP STYLE OIL HOLE COVER		in.
16	1	018-0000-2191-00	A	Ball Screw Wiper		in.
17	2	013-0000-0272-00		4-40 X 1/4 Socket Set Screw Cup Point		in.
18	1	013-5000-0134-01		HIWIN BALL SCREW/BALL NUT UT 24, 25MM		in.
19	2	013-2000-0230-00		Linear Bearing Block With 4 Hole Mount Screw From Bottom (ut)		in.
20	8	013-0000-0148-00		M4 X 14 mm SHCS		in.
21	14	013-0000-0188-00		M3-0.5 X 16 mm SHCS		in.
22	1	013-2000-0072-02		24" Linear Bearing Rail (15x820 mm)(UT, STAR)		in.
23	2	018-0000-2057-00	A	SCALE MOUNTING PLATE		in.
24	4	013-0000-0125-00		10-24 X 3/4 BHSCS		in.
25	Ref	025-1000-0243-10	M	ENCODER FOR FLASH 24, STD RESOLUTION		in.
26	1	018-0000-0880-01	F	Upper Platform Mount, UT 24		in.
27	2	013-0000-0295-00		8-32 X 7/8 SHCS		in.
28	1	018-0000-1016-00	A	CABLE GUARD		in.
29	AR	013-2000-0077-00		.005 Stainless Steel Shim Washer		in.
30	2	013-0000-0282-00		1/4-20 X 3/4 BHSCS		in.

Approved by:

Date:

May 29, 2007

SEE ATTACHED 4 DRAWINGS

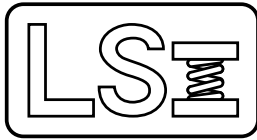

025-0000-0174-11

Frame Assembly, 24 200 lb

Parts List

Rev	By	Date	Description
	KMP	05-08-2007	

Item	Qty	Part Number	Rev	Part Name	PCB Location	Part Length
31	1	018-0000-2058-00	B	READER HEAD MOUNT		in.
32	4	013-0000-0181-00		8-32 X 1/2 SHCS		in.
33	1	013-1000-0012-00		1/4-28 Grease Fitting		in.
34	1	018-0000-2054-00	E	UT Top Support Plate		in.
35	6	013-2000-0203-00		Belville Washer, OD 1.326, ID .882		in.
37	1	018-0000-1327-02	C	Key 1/8 X 1/8 X .750		in.
38	1	013-2000-0202-00		Thrust Washer		in.
39	1	013-0000-0114-00		5/16-18 X 3/4 BHSCS		in.
40	2	013-0000-0020-00		4-40 X 1/4 Button Head Cap Screw		in.
41	Ref	025-1000-0304-01	D	Smart Cell Cable Assembly,FLASH		in.
47	8	013-0000-0097-00		10-32 X 1/2 BHSCS		in.
51	6	013-0000-0196-00		10-32 X 1/2 SHCS		in.
52	1	018-0000-1026-00	B	GEAR MOUNT END COVER		in.
54	4	013-0000-0074-00		10-32 X 1 3/4 SHCS		in.
56	24	013-0000-0026-00		10-24 X 1/2 BHSCS		in.
58	4	013-0000-0246-00		10-24 X 5/8 SHCS		in.
60	1	018-0000-1026-01	B	GEAR MOUNT END COVER		in.
61	12	013-0000-0077-00		6-32 X 1/4 Button Head Cap Screw		in.
63	1	013-0000-0291-00		4-40 X 3/4 SHCS		in.
64	1	018-0000-2072-00	B	LATCH RELEASE KNOB		in.
65	2	013-0000-0318-00		5/16-18 X 5/16 FTDT SSS Self Locking		in.
66	2	013-0000-0319-00		SPRING .240Ø x .500		in.
67	2	018-0000-2063-00	A	LATCH PIN		in.
68	2	018-0000-2069-00	C	Latch Spacer		in.
69	2	018-0000-2060-01		Shield Latch		in.
70	1	018-0000-2059-01		UT 24 Shield		in.
71	1	018-0000-2062-01		Latch Release, UT 24		in.
72	29	013-0000-0028-00		8-32 X 1/4 BHSCS		in.
73	1	018-0000-2065-01		Shield Hinge, UT24		in.
74	1	018-0000-2064-01		HINGE MOUNT, UT 24		in.

Approved by:

Date:

May 29, 2007

SEE ATTACHED 4 DRAWINGS

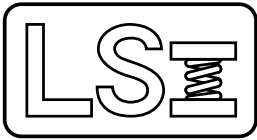

025-0000-0174-11

Frame Assembly, 24 200 lb

Parts List

Rev	By	Date	Description
	KMP	05-08-2007	

Item	Qty	Part Number	Rev	Part Name	PCB Location	Part Length
75	2	013-0000-0029-00		8-32 X 1/2 Button Head Cap Screw		in.
76	2	018-0000-2061-00	B	Shield Pin		in.
77	Ref	025-1000-0395-00	A	Cable UT Door Interlock Switch		in.
78	2	013-2000-0131-00		#4 FLAT WASHER		in.
79	2	013-0000-0018-00		4-40 X 1/2 BHSCS		in.
80	1	018-0000-0920-00	E	Back Cover UT24		in.
81	1	018-0000-0923-00	A	SIDE COVER PLATE SUPPORT		in.
82	1	013-0000-0128-00		1/4-20 X 3/8 BHSCS		in.
83	1	018-0000-2717-01		Mount Guard, Flash 11 - 24		in.
84	1	018-0000-2717-02		Slide Guard, Flash 11 -24		in.
85	1	018-0000-2717-03		Guard Stop, Flash 24		in.
86	1	018-0000-0922-00	C	SIDE COVER PLATE, UT24-50		in.
87	4	018-0000-2727-00		Guard Rail, Flash 11 - 24		in.
88	20	013-0000-0157-00		6-32 X 3/8 SHCS		in.
89	5	013-3000-0017-00		Cable Clamp, 3/8 Dia.		in.
90	1	018-0000-2728-00	A	Ball Screw Spacer, Flash 11 & 24		in.
91	Ref	025-1000-0173-03	P	200 lb UT Motor Assembly, UT11		in.
92	Ref	025-1000-0406-00	D	Motor Power / Drive Assembly (200 LB UNIT)(Flash)		in.
93	2	018-0000-1027-00	B	MOTOR STAND-OFF		in.
94	1	018-0000-1028-01	A	SMALL MOTOR MOUNTING PLATE		in.
95	1	018-0000-1029-04	H	Pulley (13-5-60), Steel Only(.596/.595ø)		in.
96	1	018-0000-1029-06	H	PULLEY(13-5-61) (.25Ø STK)		in.
97	1	013-5000-0031-00		Timing Belt - Positive Drive 110XL		in.
98	1	018-0000-2738-00		Travel Stop, Flash 24		in.

Approved by:

Date:

May 29, 2007

SEE ATTACHED 4 DRAWINGS

Printed on 08-23-2007, 3:14:38 PM by KMP

Page 7 of 7

REV	DATE	DESCRIPTION	DRW	APP
		SEE SHEET 2		

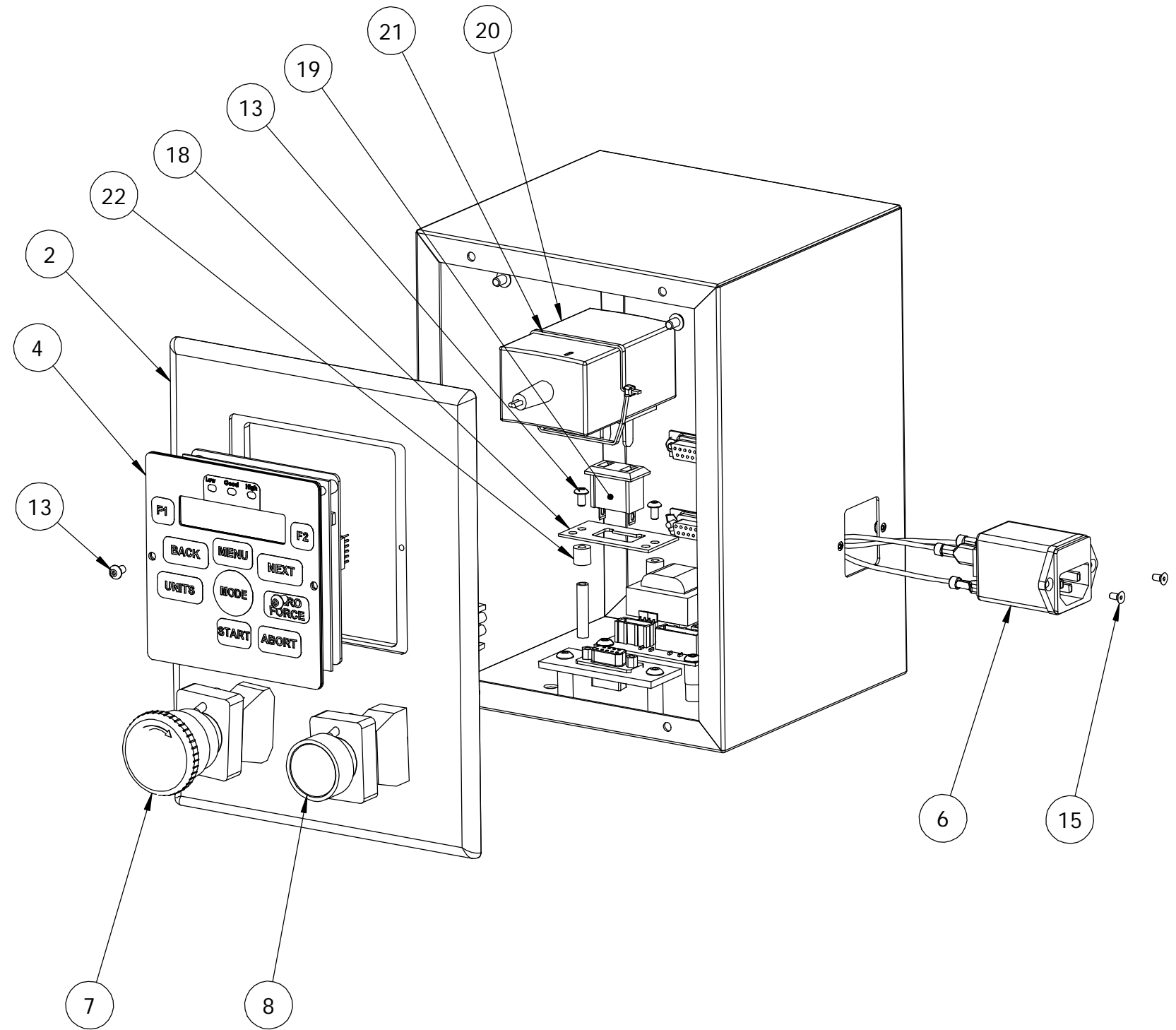
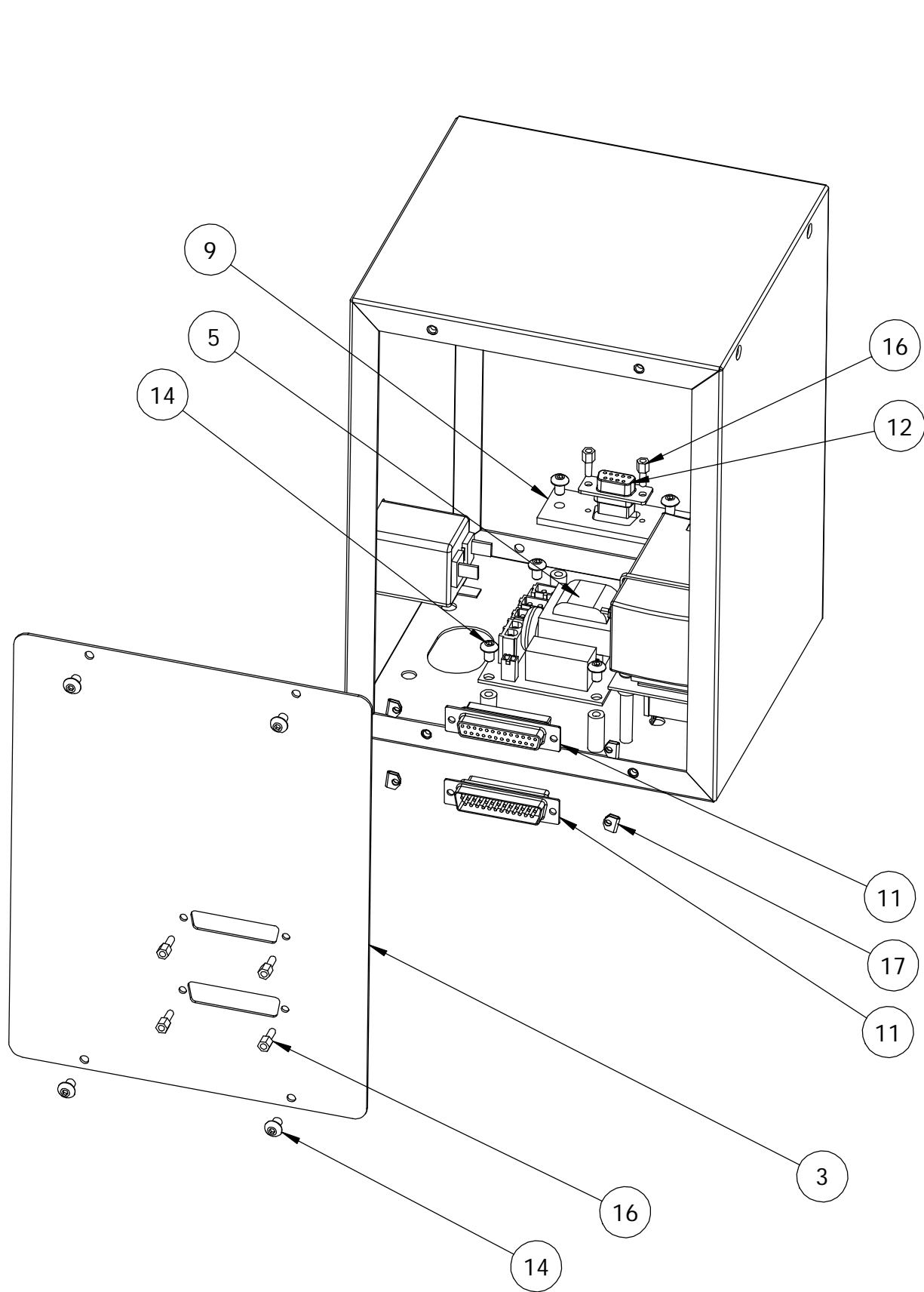

UNLESS OTHERWISE SPECIFIED DIMENSIONS ARE IN INCHES TOLERANCES ARE: .XX ± .01 .XXX ± .005	 LARSON SYSTEMS INC. 10073 Baltimore St. NE PH. 763-780-2131 Mpls., MN 55449 FAX. 763-780-2182		
			APPROVALS
MATERIAL -	DRAWN KMP	10-2-06	Super Force Meter SDHT for Auto. Tester
FINISH -	APP.		B DWG. NO. 025-0000-0342-07C
HEAT TREAT	APP.		SCALE: NONE SHEET 1 OF 2

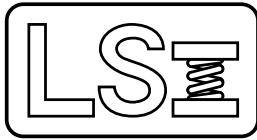

025-0000-0342-07 C

Flashlite Computer Assembly

Parts List

Rev	By	Date	Description
	KMP	04-21-2006	
A	KMP	10-19-2006	Add Item 18, 19, 20
B	KMP	01-02-2007	Add Item 21 Change Item 11 025-1-0551-00 was 25-1-0287-00 and Delete Item 10,
C	KMP	02-26-2007	Change Items 6 was 25-1-0500-00, 7 was 25-1-0501-00, 8 was 25-1-0502-00, 12 was 9-0-0073-00, 13 was 13-0-0077-00, 20 was 25-1-0396-00. Add Item 22, 23

Item	Qty	Part Number	Rev	Part Name	PCB Location	Part Length
1	1	018-0000-2893-00	B	Enclosure, Automatic SDHT		in.
2	1	018-0000-2894-00	A	Computer Front Bezel, Automatic SDHT		in.
3	1	018-0000-2895-00		Enclosure back Panel, Automatic SDHT		in.
4	1	025-0000-0684-00		Front Panel Assembly , Flashlite		in.
5	Ref	025-1000-0540-00	A	AC DISTRIBUTION MODULE, FLASH & UT		in.
6	Ref	025-1000-0500-10	C	Power Entry 120V Cable, Flashlite		in.
6	Ref	025-1000-0500-11	C	Power Entry 230V Cable, Flashlite		in.
7	Ref	025-1000-0501-02	A	E-Stop Cable, FLASH		in.
8	Ref	025-1000-0502-02	C	ON Switch Cable FLASH		in.
9	1	018-0000-2865-00		Linear Encoder Bracket, Flash		in.
11	1	025-1000-0551-00		FLASHLITE Internal, RS232, Motor, Door, Automation Cable		in.
12	1	025-1000-0304-02	D	SMART CELL CABLE ASSEMBLY, SDHT		in.
13	4	013-0000-0021-00		6-32 X 5/8 BHSCS		in.
14	14	013-0000-0028-00		8-32 X 1/4 BHSCS		in.
15	2	013-0000-0015-00		4-40 X 1/4 FHSCS		in.
16	6	013-1000-0010-00		Female Screw Lock		in.
17	4	013-1000-0009-00		Mounting Clamp and Screw		in.
18	1	018-0000-2867-00	B	AC Power Adapter Bracket, Flash - SDHT		in.
19	1	008-2000-0016-00		POWER OUTLET, SCHURTER		in.
20	1	025-1000-0560-00		FLASHLIGHT Power Supply 100-240 VAC 50-60 Hz		in.
21	1	013-4000-0008-00		Cable Tie - .095 x 14.0" long		in.
22	1	012-0000-0011-00		Nylon spacer		in.
23	1	017-0000-0029-02	A	Emergency Stop / Power On / Warning Label		in.

Approved by:

Date:

March 9, 2007

SEE ATTACHED DRAWING

Printed on 03-09-2007, 9:08:38 AM by DAL

Page 2 of 2

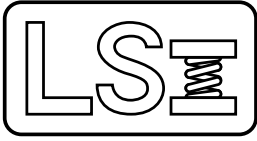

050-0000-0135-00 A
FLASH LITE 24 - 1,000 lb

Parts List

Rev	By	Date	Description
	DAL	11-11-2006	
A	DAL	07-19-2010	del 018-0000-2477-00, 013-0000-0231-00, add 059-0000-0009-00

Item	Qty	Part Number	Rev	Part Name	PCB Location	Part Length
1	1	025-0000-0174-01	G	Frame Assembly, 24 1,000 lb		in.
2	1	025-0000-0342-07	C	Flashlite Computer Assembly		in.
3	1	025-2000-0130-00	B	Electrical Schematic, FLASHLIGHT 11/24 Servo, 120/240 VAC		in.
4	1	060-1000-0087-00		User Manual - FLASH Lite		in.
5	1	060-2000-0024-00		Parts List - FLASH 11		in.
6	1	025-6000-0029-00	A	Sticker Assembly - FLASH LITE		in.
7	1	059-0000-0009-00	C	Shipping Crate -Flash 24		in.

Approved by: 

Date: July 20, 2010

REV	DATE	DESCRIPTION	DRW	APP
		SEE SHEET 5		

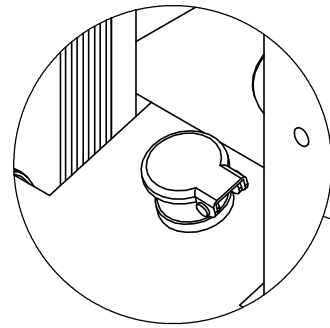

NOTE: 1. ADD OIL TO ITEM 15
AFTER ASSY

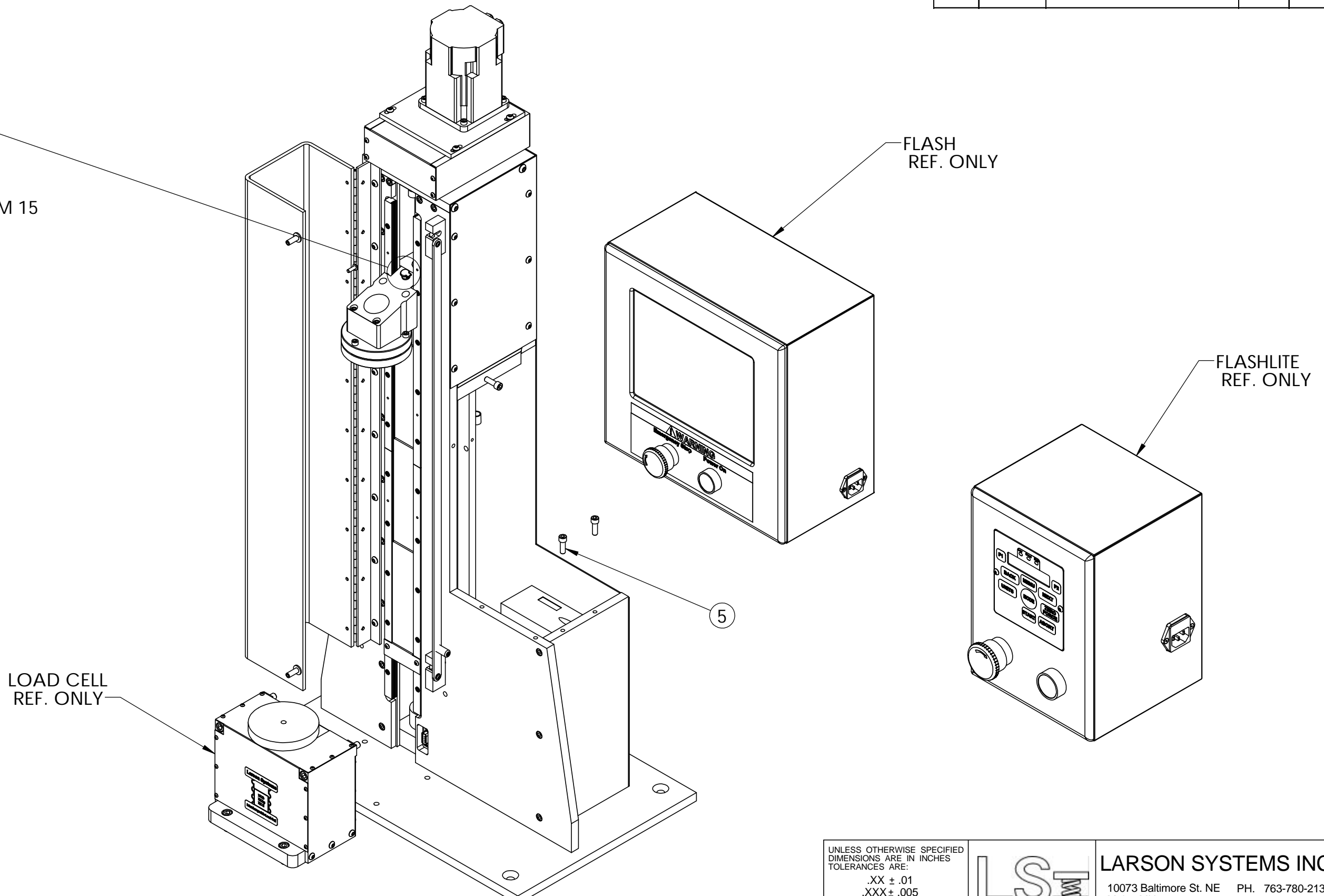

UNLESS OTHERWISE SPECIFIED DIMENSIONS ARE IN INCHES TOLERANCES ARE: .XX ± .01 .XXX ± .005	 LARSON SYSTEMS INC. 10073 Baltimore St. NE PH. 763-780-2131 Mpls., MN 55449 FAX. 763-780-2182		
			FRAME ASSEMBLY 24 1,000 lb
MATERIAL	APPROVALS	DATE	B DWG. NO. 025-0000-0174-01F
FINISH	DRAWN MEM	12-03-03	
HEAT TREAT	APP.		SCALE: NONE
	APP.		SHEET 1 OF 7

NOTES:
 1. SQUARE UP ASSEMBLY USING
 FIXTURE & PROCEDURE 060-4000-0035

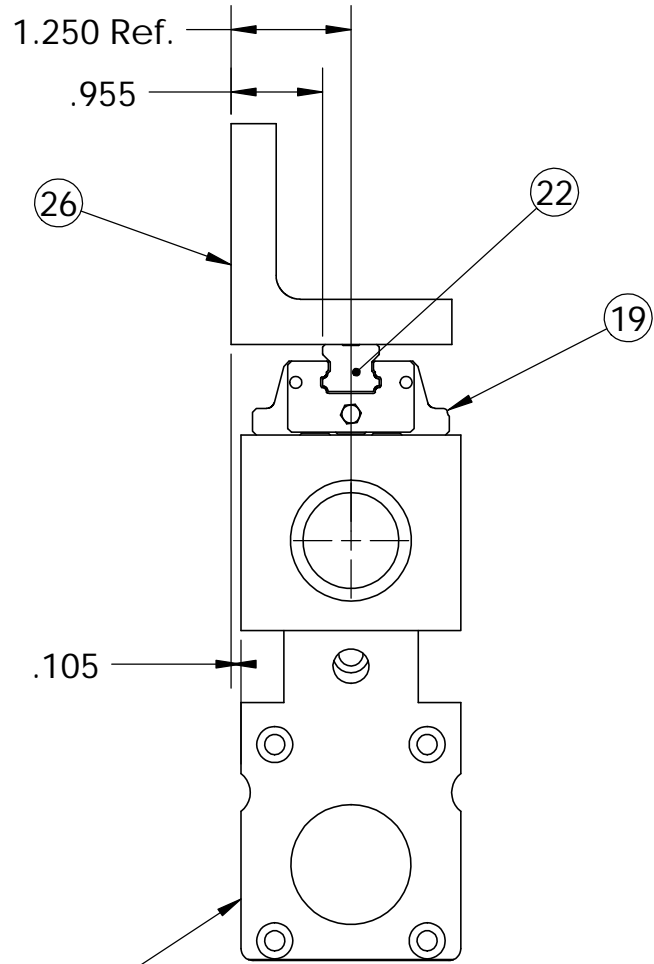
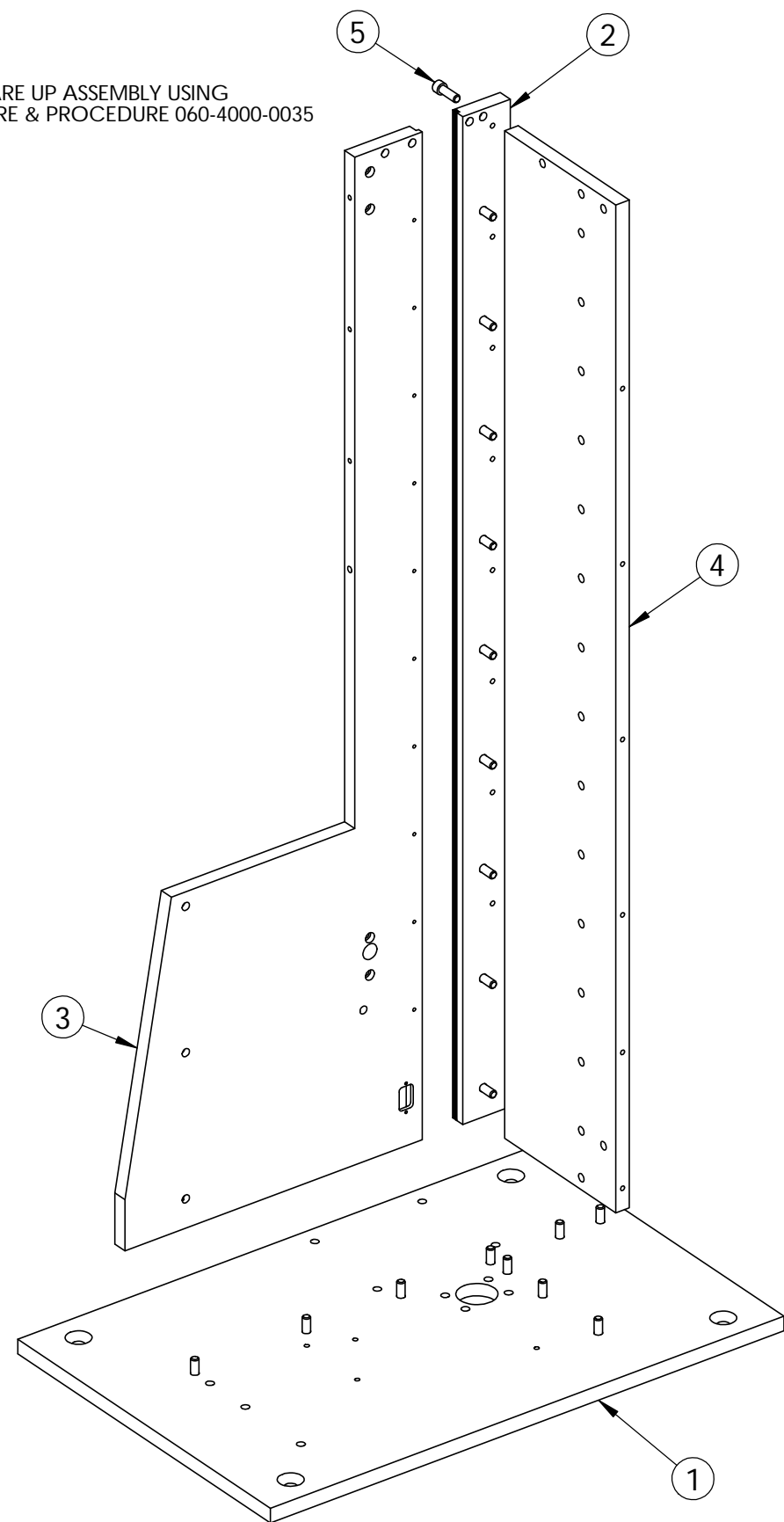

NOTES:
 1. ALIGN ITEMS 13, 22 & 26 TO ACHIEVE
 DIM .955 & .105
 2. GREASE ITEM 8
 3. NOTICE ORIENTATION OF BEARINGS,
 ITEM 8
 4. GREASE SURFACES OF ITEM 7 THEN
 FASTEN ITEM 6, TORQUE 40 FT/LB
 5. TIGHTEN FINGERTIGHT ITEM 9 TO 12
 6. TIGHTEN BALL NUT, ITEM 18 TO 40 FT/LB
 7. NOTICE ORIENTATION OF ITEM 15

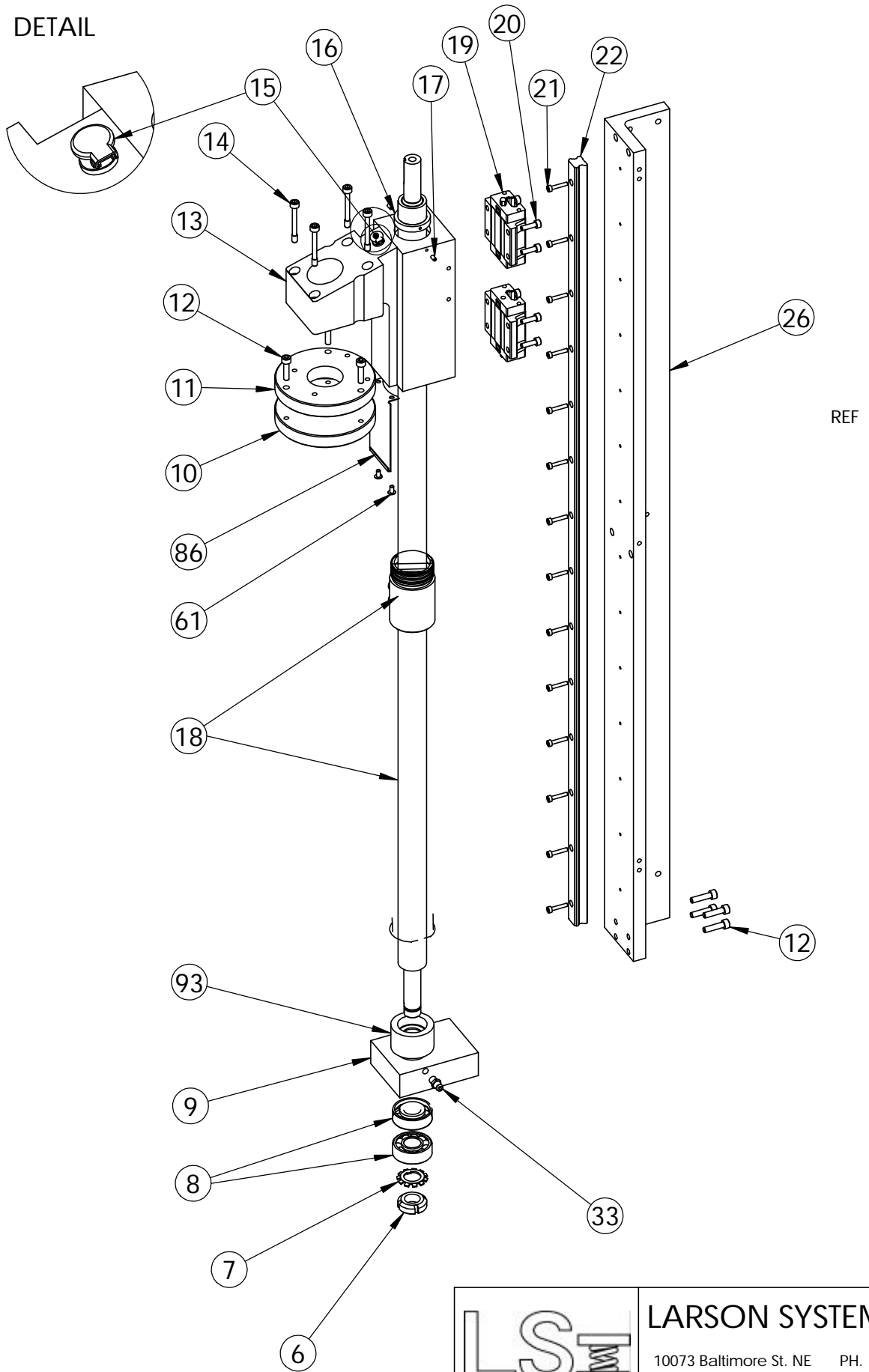
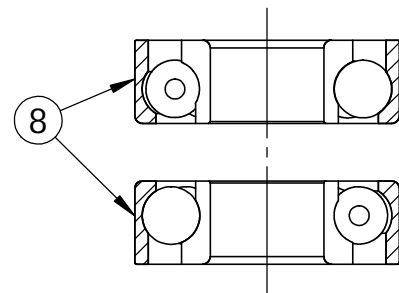

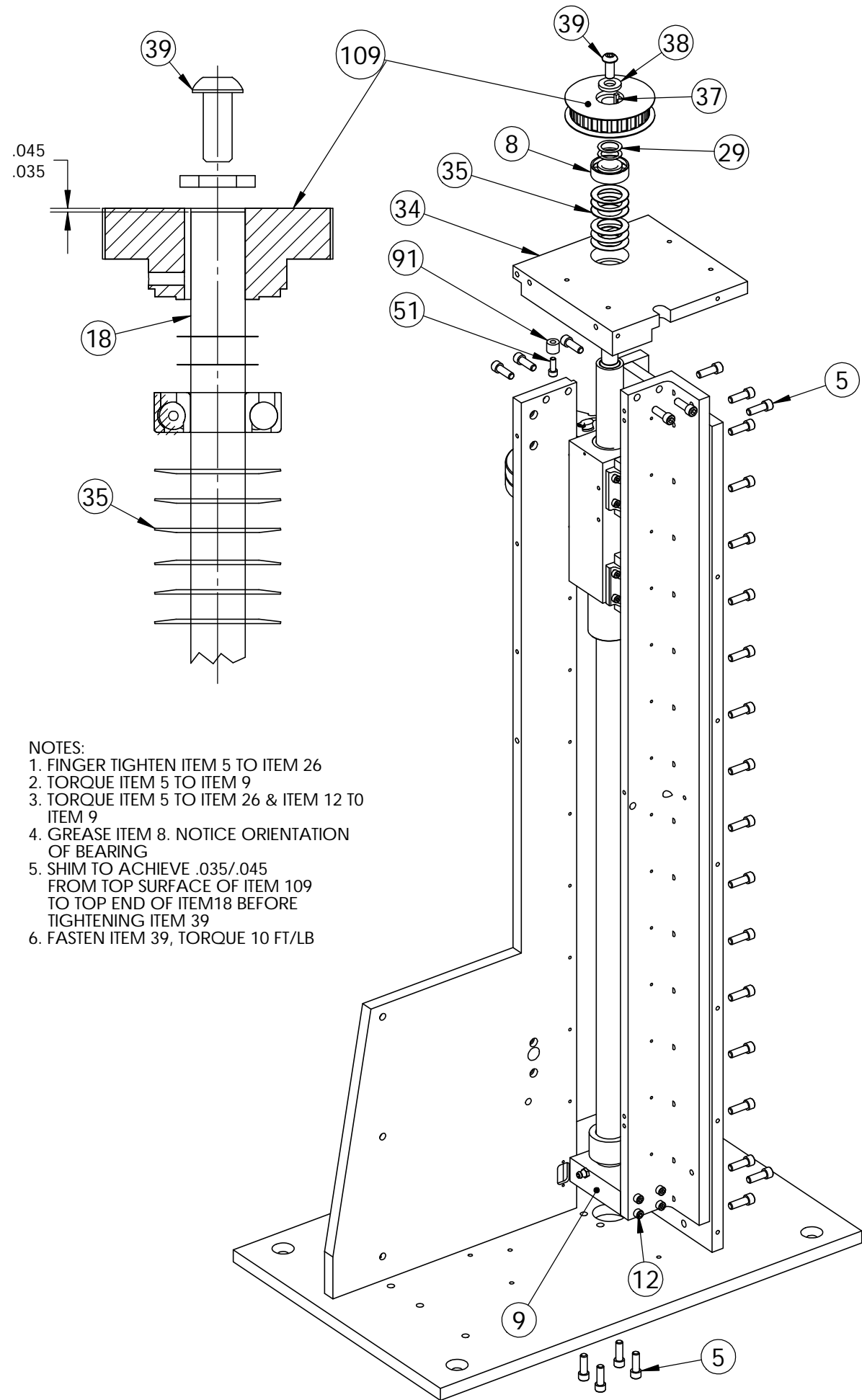

- NOTES:
 1. FINGER TIGHTEN ITEM 5 TO ITEM 26
 2. TORQUE ITEM 5 TO ITEM 9
 3. TORQUE ITEM 5 TO ITEM 26 & ITEM 12 TO ITEM 9
 4. GREASE ITEM 8. NOTICE ORIENTATION OF BEARING
 5. SHIM TO ACHIEVE .035/.045 FROM TOP SURFACE OF ITEM 109 TO TOP END OF ITEM 18 BEFORE TIGHTENING ITEM 39
 6. FASTEN ITEM 39, TORQUE 10 FT/LB

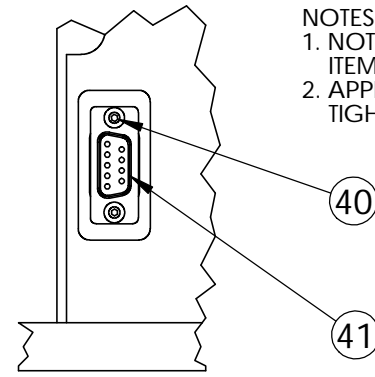

- NOTES:
 1. NOTICE ORIENTATION OF CONNECTOR, ITEM 41
 2. APPLY LOCKTITE 242 TO ITEM 40, TIGHTENING, THEN LOOSEN 1/2 TURN

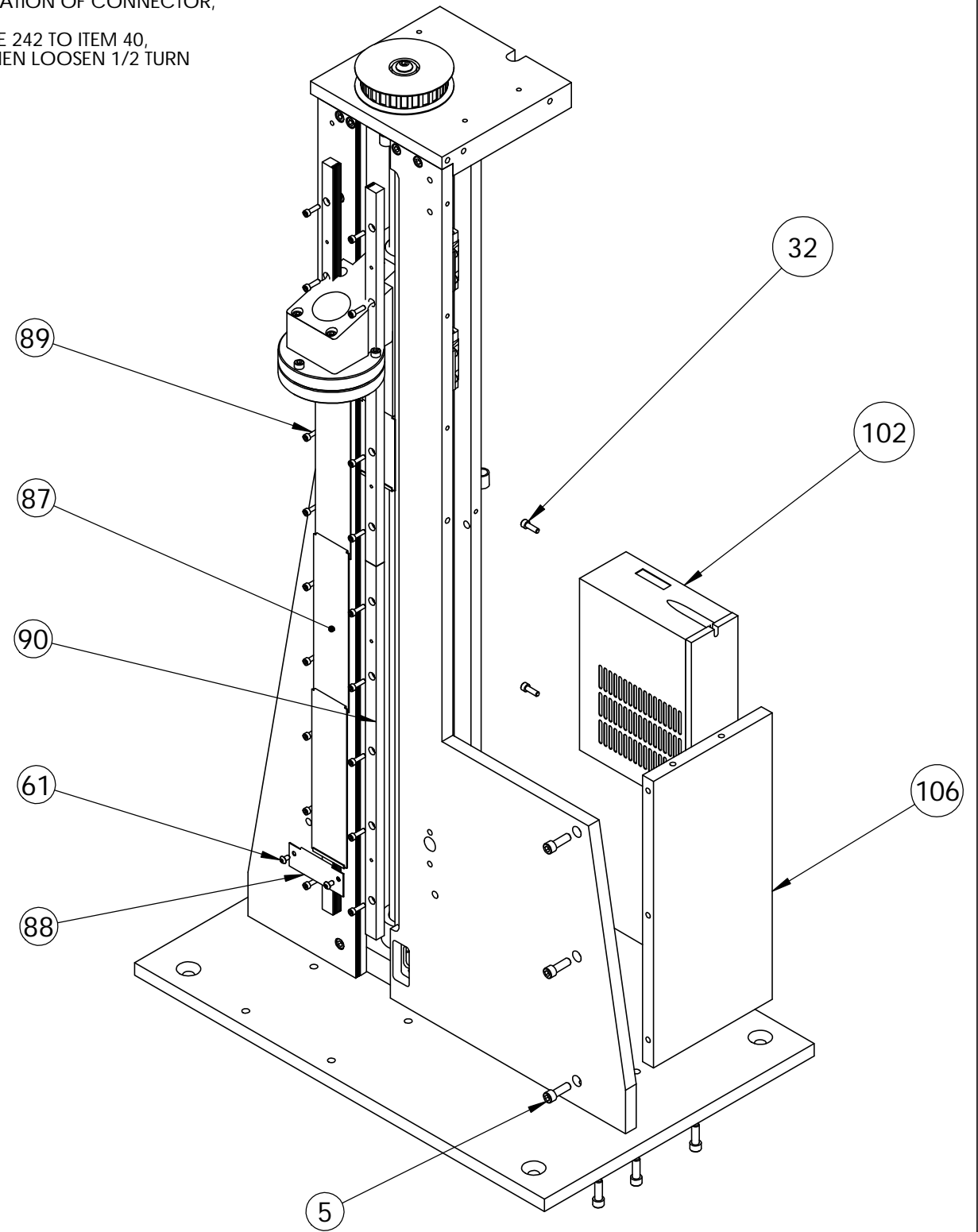

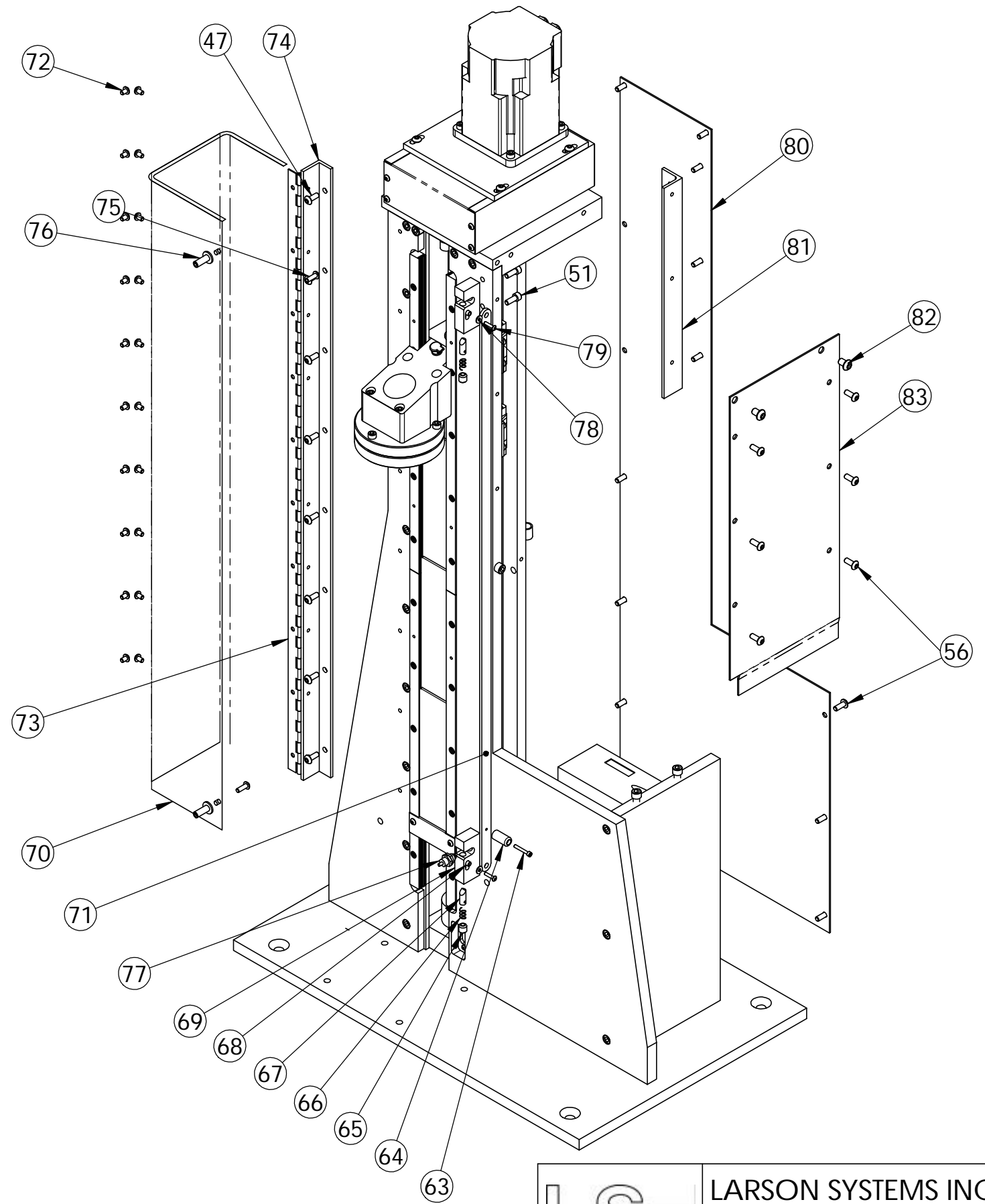
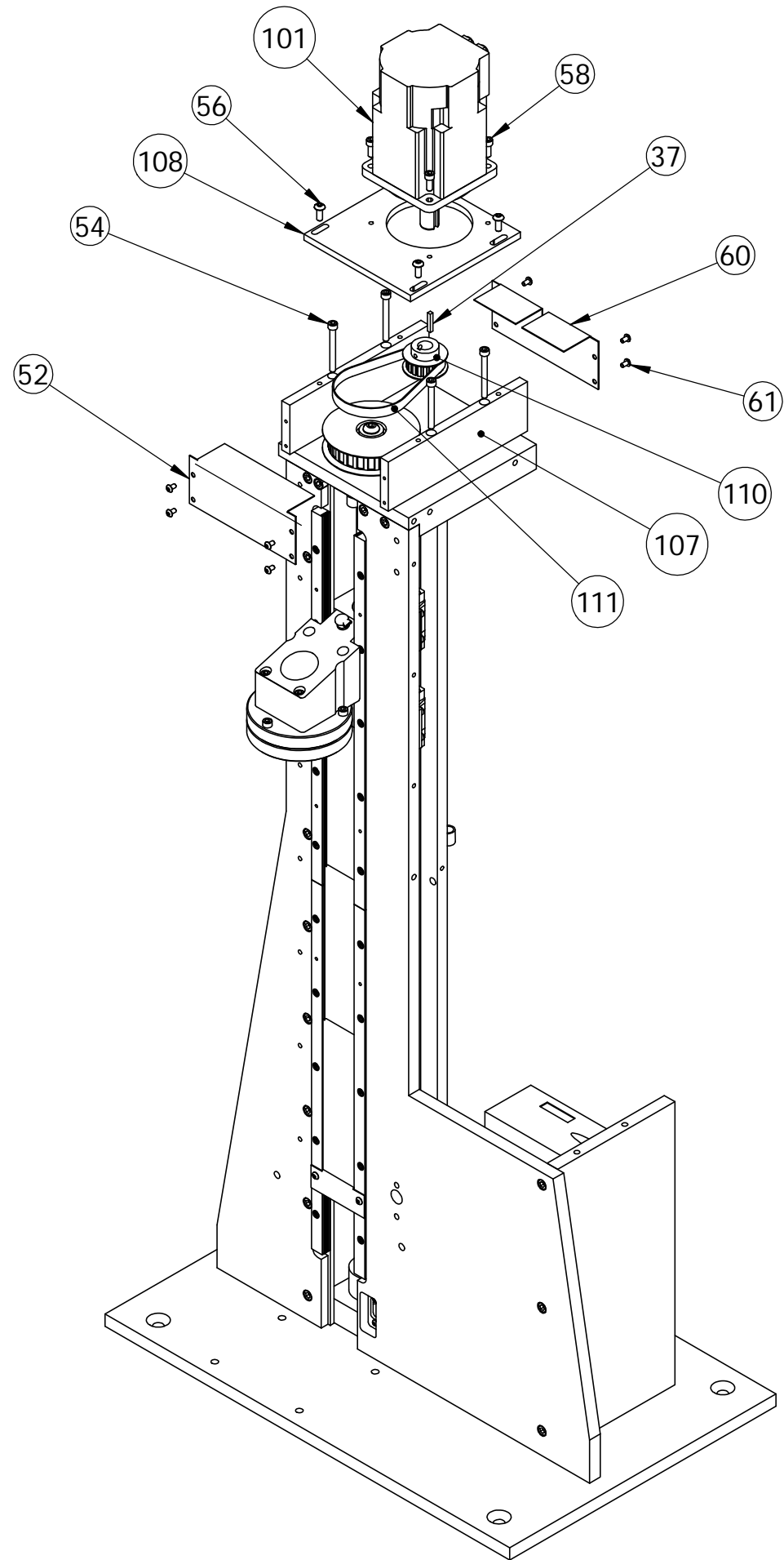

	LARSON SYSTEMS INC.	
	10073 Baltimore St. NE Mpls., MN 55449	PH. 763-780-2131 FAX. 763-780-2182
B	SCALE: NONE	DWG. NO. 025-0000-0174-01F
		SHEET 4 OF 7

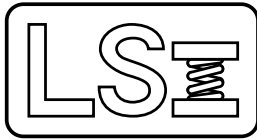

025-0000-0174-01 F

Frame Assembly, 24 1,000 lb

Parts List

Rev	By	Date	Description
C	KMP	05-23-2005	Added Item 91 Travel Stop (to upper travel) and Item 92 Cable Clamp. change Item 51 Qty to (7) was (6) and Item 72 Qty 25 was 20. Change Item 45 to 025-1000-0406-00, -02 Power supply was 025-1000-0357-00, -01
D	KMP	05-17-2006	Change Item 41 25-1-304-01 was 25-1-0033-00, Item 42 25-1-0501-00 was 7-0-0035-00. Delete Item 36, 44, 45, 53, 55, 57, 59, 62, 84. Add Item 93 THRU 111
E	KMP	09-15-2006	New Flash Computer, Delete Items 42, 43, 49, 50, 85, 103, 105. Item 61 was Qty 10 and Item 89 was 13-0-0084-00,
F	KMP	05-15-2007	Update to New Servo Motor and Drive, move 200 lb Flash 11 onto 025-0-0174-10. Eliminate Linear Encoder delete Items 23, 24, 25, 27, 28, 30, 31, 94, 95, 96, 97, 98, 99, 100, 104. Item 52 was 18-0-1026-00, Item 60 was

Item	Qty	Part Number	Rev	Part Name	PCB Location	Part Length
1	1	018-0000-0176-04	Z	Base Plate		in.
2	1	018-0000-0171-03	G	LEFT SUPPORT, UT24		in.
3	1	018-0000-0339-01	J	Right Support, UT 24		in.
4	1	018-0000-0887-01	E	LEFT BACK SUPPORT, UT24		in.
5	56	013-0000-0032-00		1/4-20 X 3/4 SHCS		in.
6	1	013-2000-0104-00		Lock Nut		in.
7	1	013-2000-0105-00		Lock Washer		in.
8	3	013-2000-0090-00	A	Angular Contact Bearing		in.
9	1	018-0000-2055-00	D	UT Bearing Block		in.
10	1	018-0000-1009-00	E	Upper Platform, 5/16-18		in.
11	1	018-0000-0164-00	M	3.5" Upper Platform		in.
12	7	013-0000-0115-00		10-32 X 3/4 SHCS		in.
13	1	018-0000-2056-00	G	Upper Platform Mount		in.
14	4	018-0000-1732-03	B	10-32 Custom Screws for Platform Alignment		in.
15	1	013-1000-0025-00		CUP STYLE OIL HOLE COVER		in.
16	1	018-0000-2191-00	A	Ball Screw Wiper		in.
17	2	013-0000-0272-00		4-40 X 1/4 Socket Set Screw Cup Point		in.
18	1	013-5000-0134-01		HIWIN BALL SCREW/BALL NUT UT 24, 25MM		in.
19	2	013-2000-0230-00		Linear Bearing Block With 4 Hole Mount Screw From Bottom (ut)		in.
20	8	013-0000-0148-00		M4 X 14 mm SHCS		in.
21	14	013-0000-0188-00		M3-0.5 X 16 mm SHCS		in.
22	1	013-2000-0072-02		24" Linear Bearing Rail (15x820 mm)(UT, STAR)		in.
26	1	018-0000-0880-01	F	Upper Platform Mount, UT 24		in.
29	AR	013-2000-0077-00		.005 Stainless Steel Shim Washer		in.
32	2	013-0000-0181-00		8-32 X 1/2 SHCS		in.
33	1	013-1000-0012-00		1/4-28 Grease Fitting		in.
34	1	018-0000-2054-00	E	UT Top Support Plate		in.
35	6	013-2000-0203-00		Belville Washer, OD 1.326, ID .882		in.
37	1	018-0000-1327-02	C	Key 1/8 X 1/8 X .750		in.
38	1	013-2000-0202-00		Thrust Washer		in.

Approved by: 

Date: May 25, 2007

SEE ATTACHED 4 DRAWINGS

Printed on 05-25-2007, 9:41:44 AM by DAL

Page 5 of 7

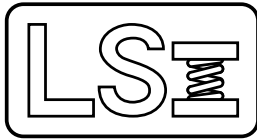

025-0000-0174-01 F

Frame Assembly, 24 1,000 lb

Parts List

Rev	By	Date	Description
C	KMP	05-23-2005	Added Item 91 Travel Stop (to upper travel) and Item 92 Cable Clamp. change Item 51 Qty to (7) was (6) and Item 72 Qty 25 was 20. Change Item 45 to 025-1000-0406-00, -02 Power supply was 025-1000-0357-00, -01
D	KMP	05-17-2006	Change Item 41 25-1-304-01 was 25-1-0033-00, Item 42 25-1-0501-00 was 7-0-0035-00. Delete Item 36, 44, 45, 53, 55, 57, 59, 62, 84. Add Item 93 THRU 111
E	KMP	09-15-2006	New Flash Computer, Delete Items 42, 43, 49, 50, 85, 103, 105. Item 61 was Qty 10 and Item 89 was 13-0-0084-00,
F	KMP	05-15-2007	Update to New Servo Motor and Drive, move 200 lb Flash 11 onto 025-0-0174-10. Eliminate Linear Encoder delete Items 23, 24, 25, 27, 28, 30, 31, 94, 95, 96, 97, 98, 99, 100, 104. Item 52 was 18-0-1026-00, Item 60 was

Item	Qty	Part Number	Rev	Part Name	PCB Location	Part Length
39	1	013-0000-0114-00		5/16-18 X 3/4 BHSCS		in.
40	2	013-0000-0020-00		4-40 X 1/4 Button Head Cap Screw		in.
41	Ref	025-1000-0304-01	D	Smart Cell Cable Assembly,FLASH		in.
47	8	013-0000-0097-00		10-32 X 1/2 BHSCS		in.
50	2	013-0000-0010-00		4-40 X 3/8 SHCS		in.
51	7	013-0000-0196-00		10-32 X 1/2 SHCS		in.
52	1	018-0000-1026-04		GEAR MOUNT FRONT END COVER, Flash 11- 24 1,000 lb		in.
54	4	013-0000-0074-00		10-32 X 1 3/4 SHCS		in.
56	24	013-0000-0026-00		10-24 X 1/2 BHSCS		in.
58	4	013-0000-0246-00		10-24 X 5/8 SHCS		in.
60	1	018-0000-1026-03		GEAR MOUNT END COVER, Flash 11- 24 1,000 lb		in.
61	8	013-0000-0077-00		6-32 X 1/4 Button Head Cap Screw		in.
63	1	013-0000-0291-00		4-40 X 3/4 SHCS		in.
64	1	018-0000-2072-00	B	LATCH RELEASE KNOB		in.
65	2	013-0000-0318-00		5/16-18 X 5/16 FTDT SSS Self Locking		in.
66	2	013-0000-0319-00		SPRING .240Ø x .500		in.
67	2	018-0000-2063-00	A	LATCH PIN		in.
68	2	018-0000-2069-00	C	Latch Spacer		in.
69	2	018-0000-2060-01		Shield Latch		in.
70	1	018-0000-2059-01		UT 24 Shield		in.
71	1	018-0000-2062-01		Latch Release, UT 24		in.
72	35	013-0000-0028-00		8-32 X 1/4 BHSCS		in.
73	1	018-0000-2065-01		Shield Hinge, UT24		in.
74	1	018-0000-2064-01		HINGE MOUNT, UT 24		in.
75	2	013-0000-0029-00		8-32 X 1/2 Button Head Cap Screw		in.
76	2	018-0000-2061-00	B	Shield Pin		in.
77	Ref	025-1000-0395-00	A	Cable UT Door Interlock Switch		in.
78	2	013-2000-0131-00		#4 FLAT WASHER		in.
79	2	013-0000-0018-00		4-40 X 1/2 BHSCS		in.
80	1	018-0000-0920-00	E	Back Cover UT24		in.

Approved by:

Date:

May 25, 2007

SEE ATTACHED 4 DRAWINGS

Printed on 05-25-2007, 9:41:44 AM by DAL

Page 6 of 7

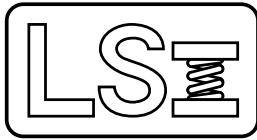

025-0000-0174-01 F
Frame Assembly, 24 1,000 lb

Parts List

Rev	By	Date	Description
C	KMP	05-23-2005	Added Item 91 Travel Stop (to upper travel) and Item 92 Cable Clamp. change Item 51 Qty to (7) was (6) and Item 72 Qty 25 was 20. Change Item 45 to 025-1000-0406-00, -02 Power supply was 025-1000-0357-00, -01
D	KMP	05-17-2006	Change Item 41 25-1-304-01 was 25-1-0033-00, Item 42 25-1-0501-00 was 7-0-0035-00. Delete Item 36, 44, 45, 53, 55, 57, 59, 62, 84. Add Item 93 THRU 111
E	KMP	09-15-2006	New Flash Computer, Delete Items 42, 43, 49, 50, 85, 103, 105. Item 61 was Qty 10 and Item 89 was 13-0-0084-00,
F	KMP	05-15-2007	Update to New Servo Motor and Drive, move 200 lb Flash 11 onto 025-0-0174-10. Eliminate Linear Encoder delete Items 23, 24, 25, 27, 28, 30, 31, 94, 95, 96, 97, 98, 99, 100, 104. Item 52 was 18-0-1026-00, Item 60 was

Item	Qty	Part Number	Rev	Part Name	PCB Location	Part Length
81	1	018-0000-0923-00	A	SIDE COVER PLATE SUPPORT		in.
82	2	013-0000-0128-00		1/4-20 X 3/8 BHSCS		in.
83	1	018-0000-0922-00	C	SIDE COVER PLATE, UT24-50		in.
86	1	018-0000-2717-01		Mount Guard, Flash 11 - 24		in.
87	2	018-0000-2717-02		Slide Guard, Flash 11 -24		in.
88	1	018-0000-2717-03		Guard Stop, Flash 24		in.
89	20	013-0000-0157-00		6-32 X 3/8 SHCS		in.
90	4	018-0000-2727-00		Guard Rail, Flash 11 - 24		in.
91	1	018-0000-2738-00		Travel Stop, Flash 24		in.
92	5	013-3000-0017-00		Cable Clamp, 3/8 Dia.		in.
93	1	018-0000-2728-00	A	Ball Screw Spacer, Flash 11 & 24		in.
101	Ref	014-2000-0028-00		AKM41 SERVO MOTOR		in.
102	Ref	011-3000-0018-00		S200 SERVO MOTOR DRIVE, 3 AMP LIMIT		in.
106	1	018-0000-0173-05		Right Back Support, Flash		in.
107	2	018-0000-1027-01	A	Motor Stand-off (2000 Lb Motor)		in.
108	1	018-0000-1028-00	B	MOTOR MOUNTING PLATE		in.
109	1	018-0000-1029-08	H	Pulley(13-5-149)(ø.596/.595) 1000 LB Pulley		in.
110	1	018-0000-1029-09	H	Pulley(13-5-150)(.626/.625) 1000LB Motor pulley		in.
111	1	013-5000-0148-00		Timing Belt 33 Th		in.

Approved by: 

Date: May 25, 2007

SEE ATTACHED 4 DRAWINGS

REV	DATE	DESCRIPTION	DRW	APP
		SEE SHEET 2		

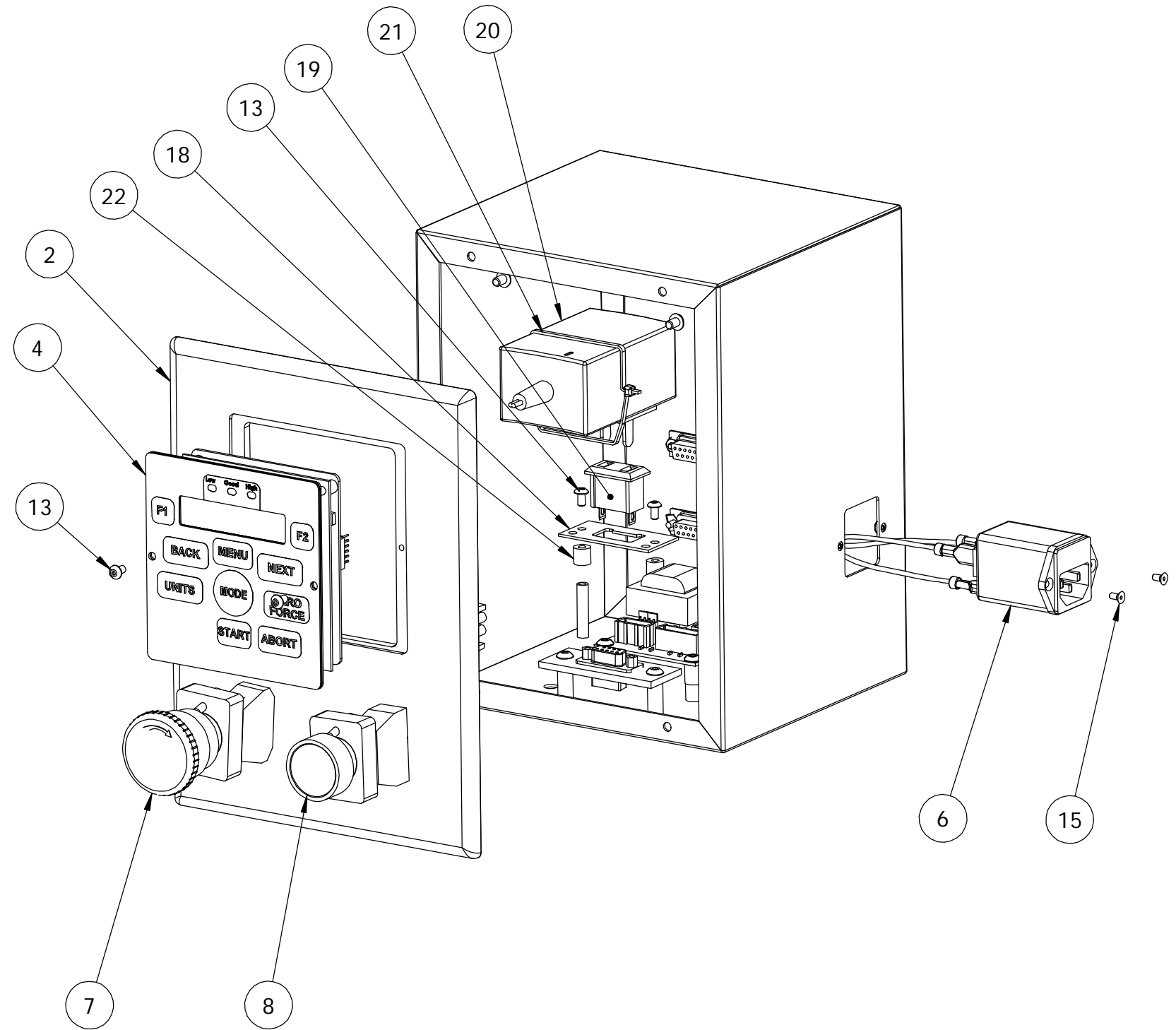
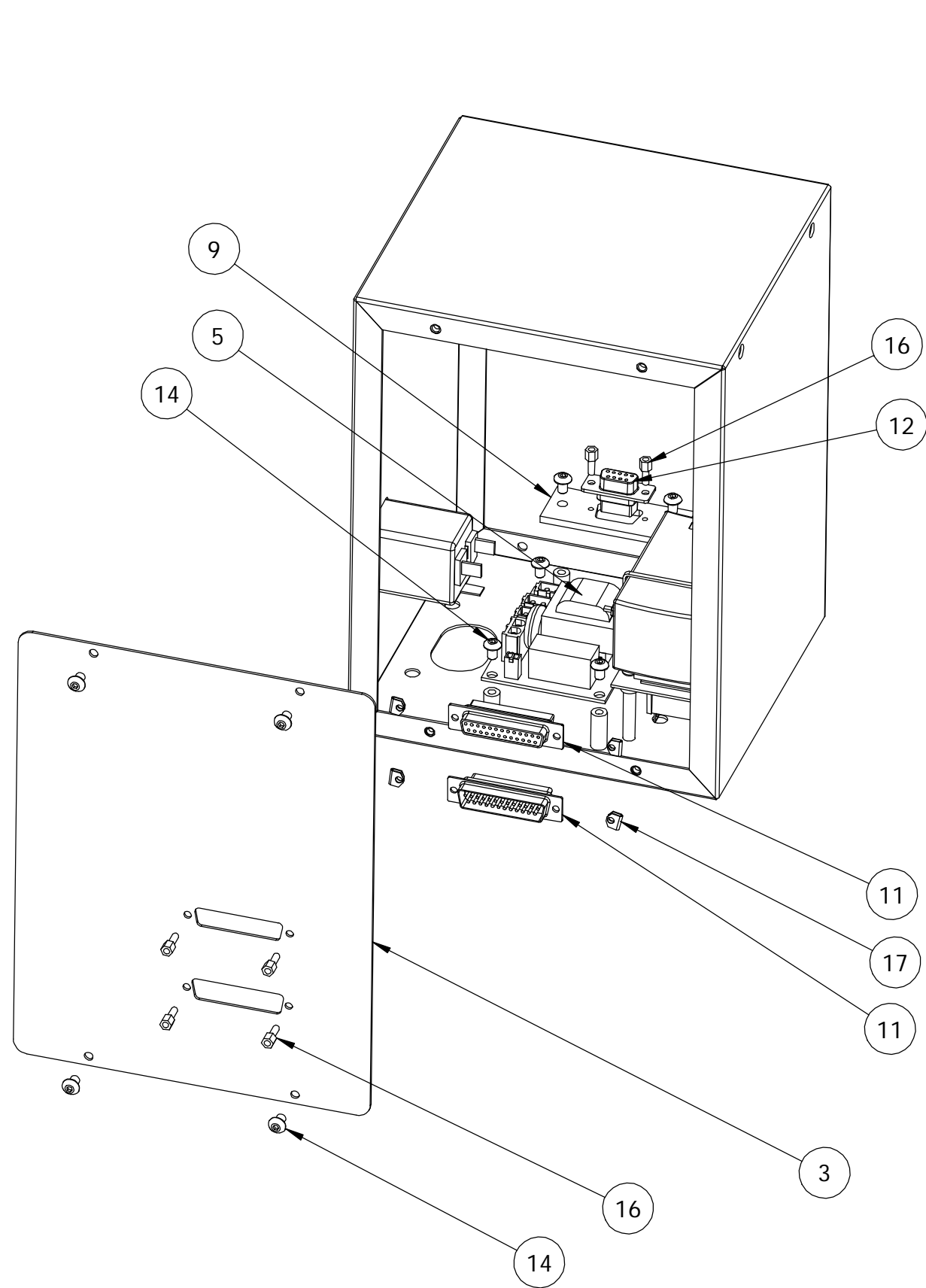

UNLESS OTHERWISE SPECIFIED DIMENSIONS ARE IN INCHES TOLERANCES ARE: .XX ± .01 .XXX ± .005		LS	LARSON SYSTEMS INC.	
MATERIAL -			10073 Baltimore St. NE PH. 763-780-2131 Mpls., MN 55449 FAX. 763-780-2182	
FINISH -		APPROVALS	DATE	Super Force Meter SDHT for Auto. Tester
HEAT TREAT		DRAWN KMP	10-2-06	
		APP.		B DWG. NO. 025-0000-0342-07C
		APP.		SCALE: NONE SHEET 1 OF 2

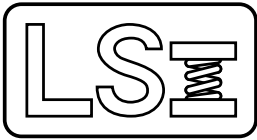

025-0000-0342-07 C
Flashlite Computer Assembly

Parts List

Rev	By	Date	Description
	KMP	04-21-2006	
A	KMP	10-19-2006	Add Item 18, 19, 20
B	KMP	01-02-2007	Add Item 21 Change Item 11 025-1-0551-00 was 25-1-0287-00 and Delete Item 10,
C	KMP	02-26-2007	Change Items 6 was 25-1-0500-00, 7 was 25-1-0501-00, 8 was 25-1-0502-00, 12 was 9-0-0073-00, 13 was 13-0-0077-00, 20 was 25-1-0396-00. Add Item 22, 23

Item	Qty	Part Number	Rev	Part Name	PCB Location	Part Length
1	1	018-0000-2893-00	B	Enclosure, Automatic SDHT		in.
2	1	018-0000-2894-00	A	Computer Front Bezel, Automatic SDHT		in.
3	1	018-0000-2895-00		Enclosure back Panel, Automatic SDHT		in.
4	1	025-0000-0684-00		Front Panel Assembly , Flashlite		in.
5	Ref	025-1000-0540-00	A	AC DISTRIBUTION MODULE, FLASH & UT		in.
6	Ref	025-1000-0500-10	C	Power Entry 120V Cable, Flashlite		in.
6	Ref	025-1000-0500-11	C	Power Entry 230V Cable, Flashlite		in.
7	Ref	025-1000-0501-02	A	E-Stop Cable, FLASH		in.
8	Ref	025-1000-0502-02	C	ON Switch Cable FLASH		in.
9	1	018-0000-2865-00		Linear Encoder Bracket, Flash		in.
11	1	025-1000-0551-00		FLASHLITE Internal, RS232, Motor, Door, Automation Cable		in.
12	1	025-1000-0304-02	D	SMART CELL CABLE ASSEMBLY, SDHT		in.
13	4	013-0000-0021-00		6-32 X 5/8 BHSCS		in.
14	14	013-0000-0028-00		8-32 X 1/4 BHSCS		in.
15	2	013-0000-0015-00		4-40 X 1/4 FHSCS		in.
16	6	013-1000-0010-00		Female Screw Lock		in.
17	4	013-1000-0009-00		Mounting Clamp and Screw		in.
18	1	018-0000-2867-00	B	AC Power Adapter Bracket, Flash - SDHT		in.
19	1	008-2000-0016-00		POWER OUTLET, SCHURTER		in.
20	1	025-1000-0560-00		FLASHLIGHT Power Supply 100-240 VAC 50-60 Hz		in.
21	1	013-4000-0008-00		Cable Tie - .095 x 14.0" long		in.
22	1	012-0000-0011-00		Nylon spacer		in.
23	1	017-0000-0029-02	A	Emergency Stop / Power On / Warning Label		in.

Approved by:

Date:

March 9, 2007

SEE ATTACHED DRAWING



Larson Systems Inc.
10073 Baltimore Street NE
Minneapolis, MN 55449-4425
www.larsonsystems.com

763-780-2131
1-877-780-2131
Fax: 763-780-2182
info@larsonsystems.com

