

# *Larson Systems Inc.*

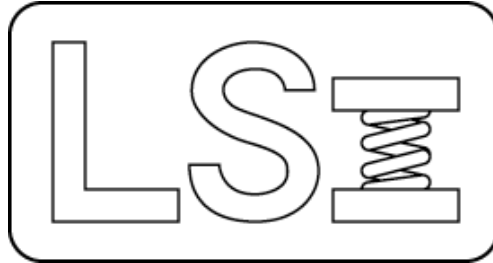

## *FLASH 48 Parts List*

*050-0000-0147-00 – 6,000 lb Whisper Drive*

*050-0000-0147-01 – 13,200 lb Whisper Drive*



| REV | DATE | DESCRIPTION | DRW | APP |
|-----|------|-------------|-----|-----|
|     |      |             |     |     |
|     |      |             |     |     |

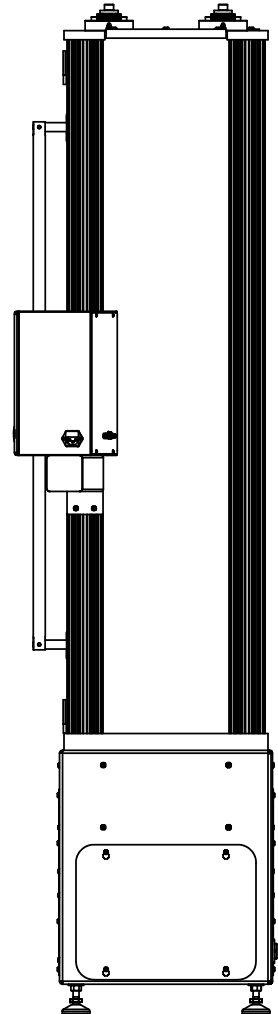
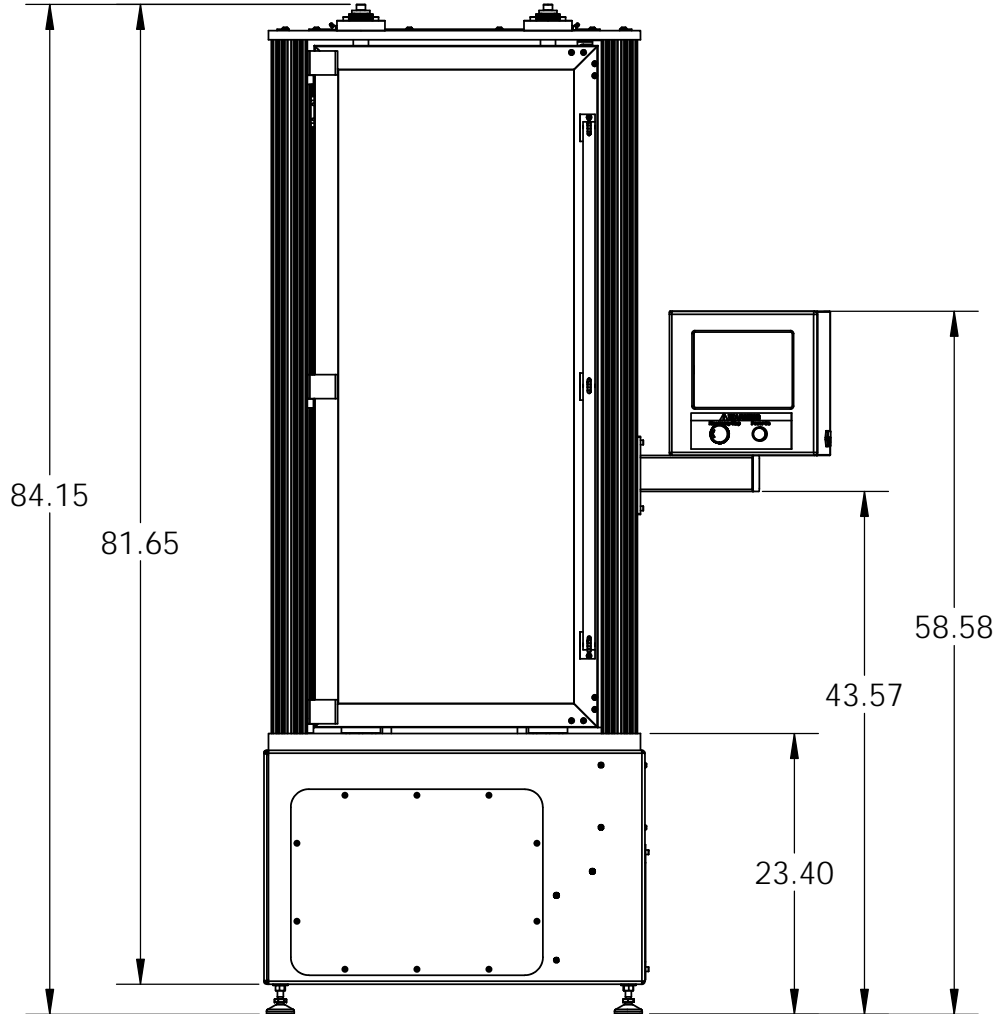
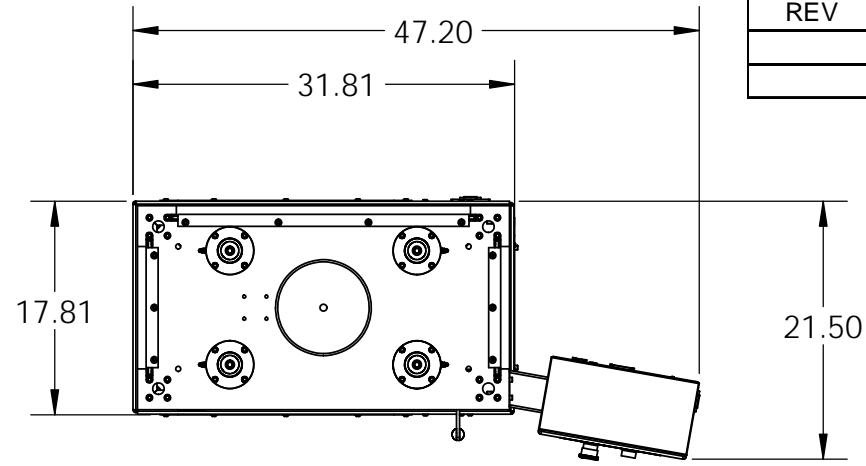
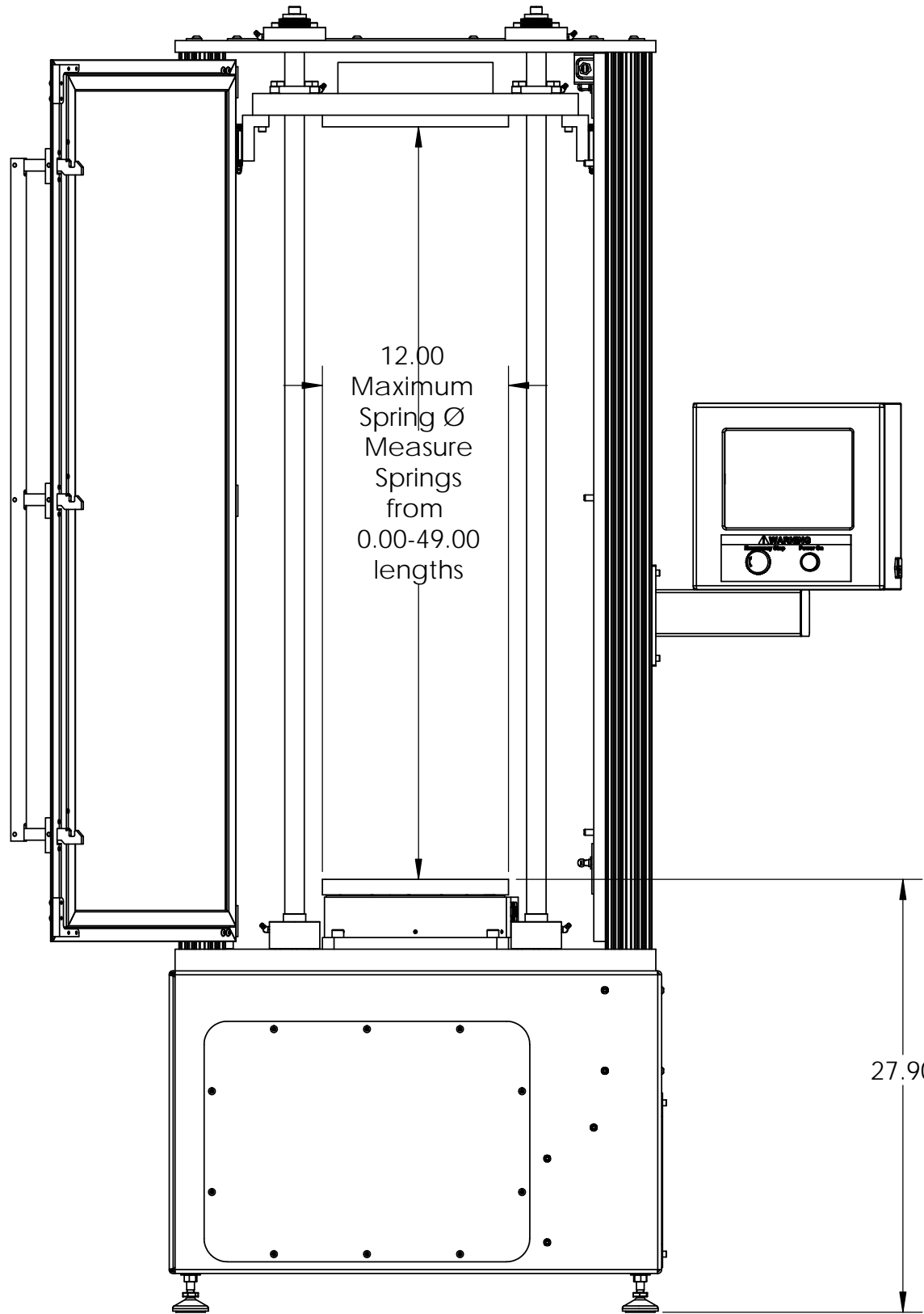

|   |          |  |             |
|---|----------|--|-------------|
|  |          | <b>LARSON SYSTEMS INC.</b><br>10073 Baltimore St. NE PH. 763-780-2131<br>Mpls., MN 55449 FAX. 763-780-2182 |             |
|   |          | <i>FLASH 48</i>  |             |
| APPROVALS   | DATE     | B DWG. NO. 025-0000-0920-XXA   | REV:        |
| DRAWN RRS   | 07-02-13 |  | SCALE: NONE |

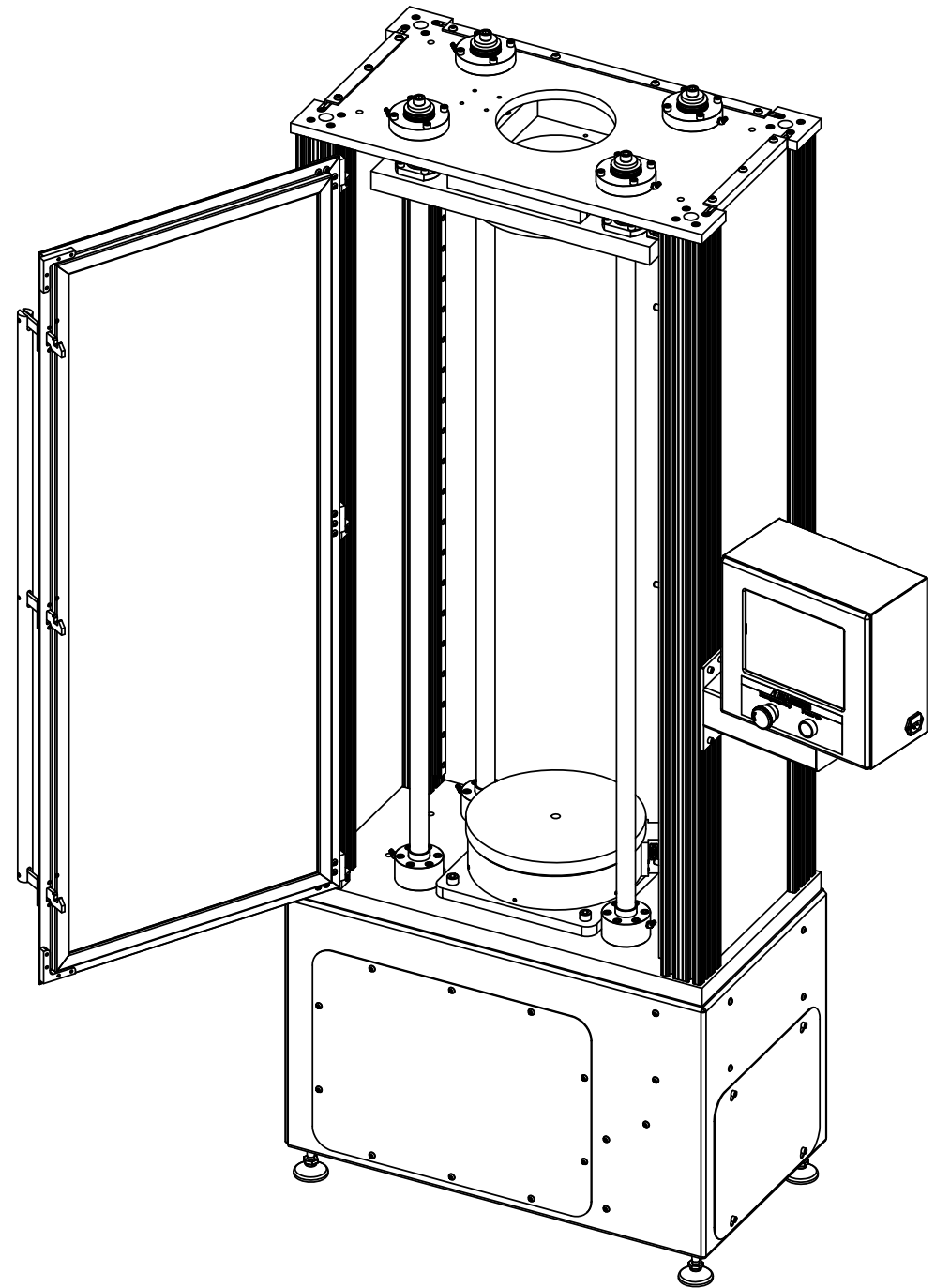
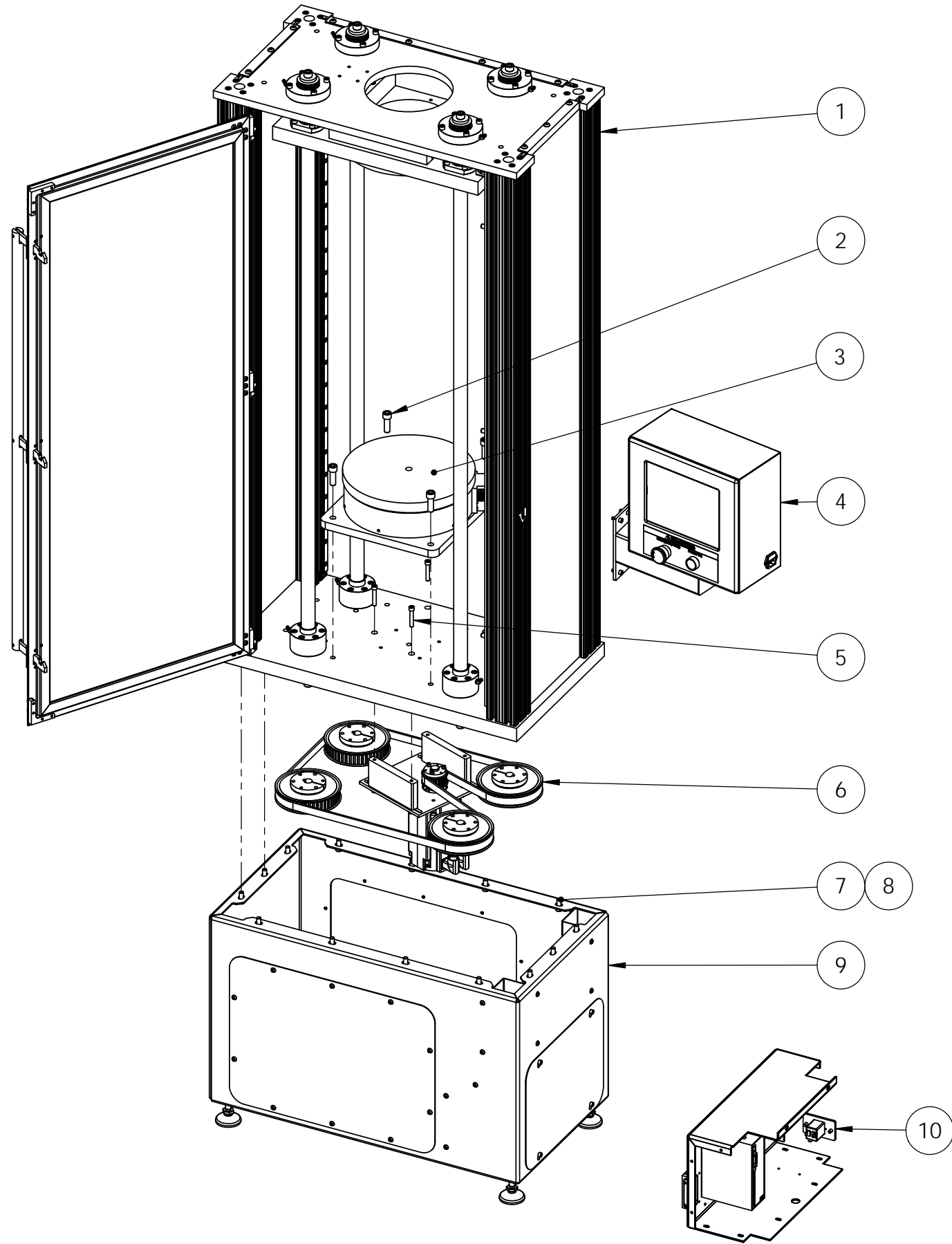

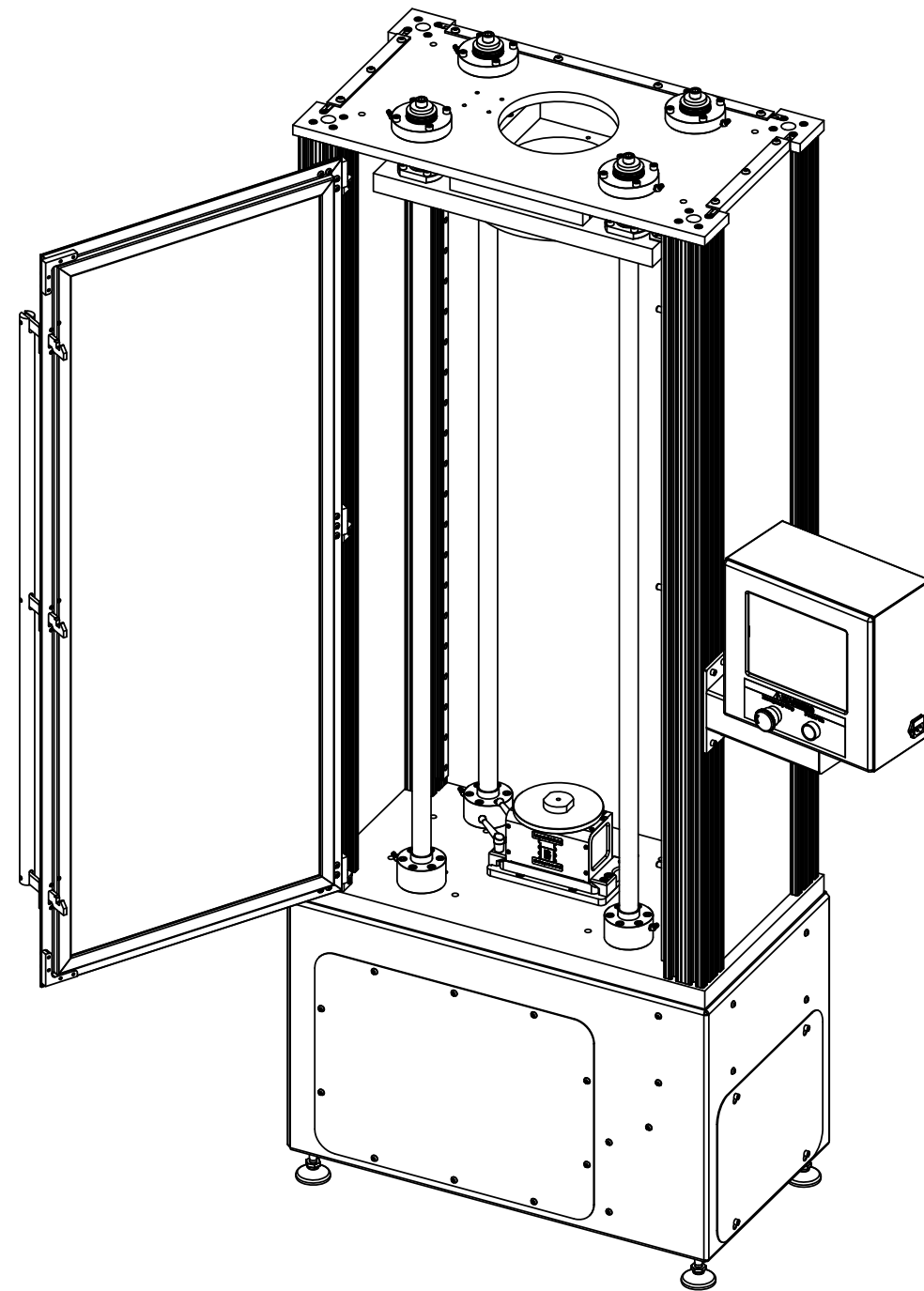
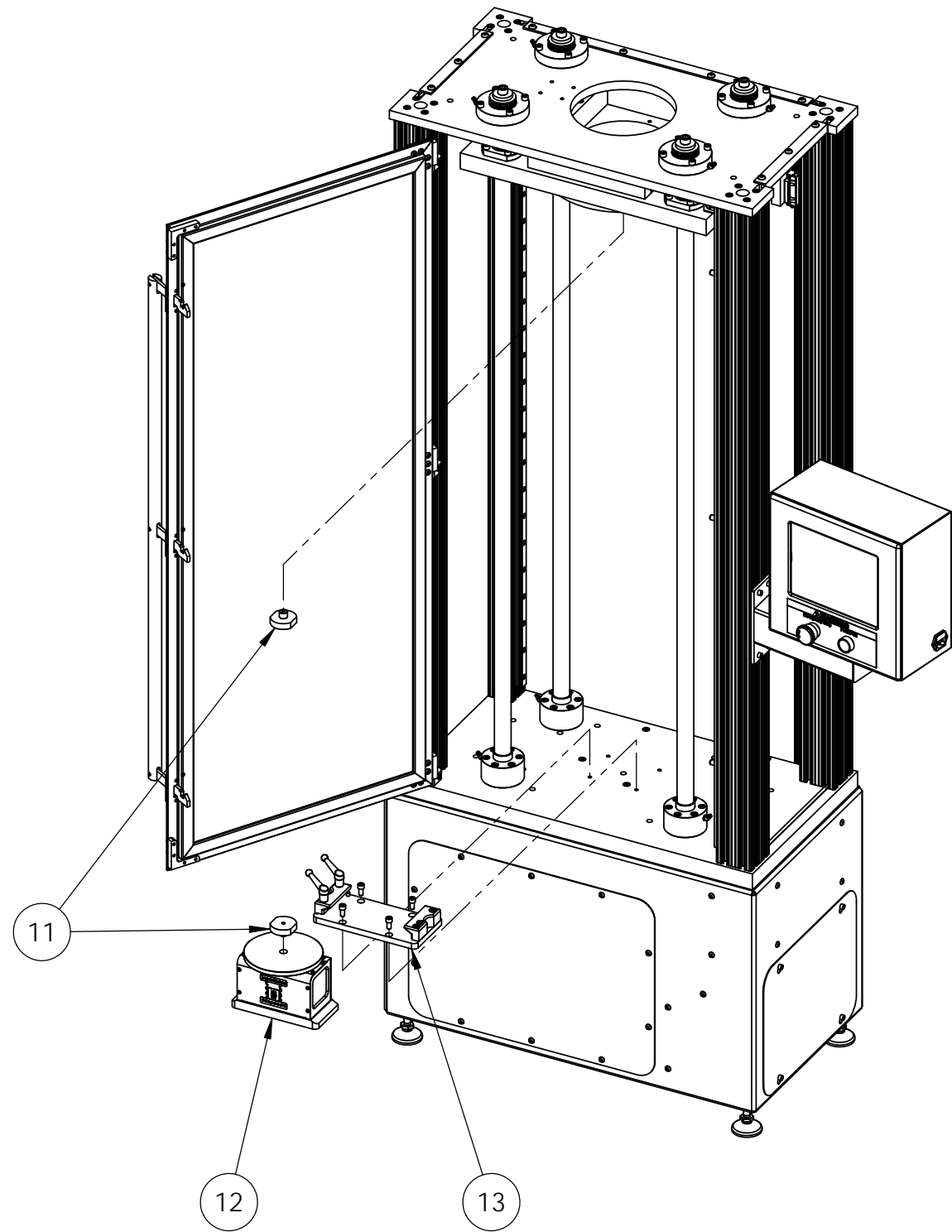

NOTE:  
 Item 12 018-0000-2029-00  
 Ø 2" platform and 5/8-18 to 5/16-18 thd adapter is only  
 supplied in multiple load cell systems when Ø 3.5"  
 platform load cells (025-0000-0814-00 to -05) are purchased  
 as well as Ø 6" platform load cells 025-0000-0814-08 to -12).



**025-0000-0920-00 A**  
FLASH 48 - 6,000

# Parts List

| Rev | By  | Date       | Description                                      |
|-----|-----|------------|--|
|     | RRS | 07-01-2013 |  |
| A   | RRS | 09-13-2013 | Item 7 was 013-0000-0167-00, is 013-0000-0245-00 |
|     |     |            |  |
|     |     |            |  |

| Item | Qty | Part Number      | Rev | Part Name  | PCB Location | Part Length |
|------|-----|------------------|-----|--|--------------|-------------|
| 1    | 1   | 025-0000-0921-00 | A   | Upper Assembly, FLASH 48                             |              | in.         |
| 2    | 4   | 013-0000-0225-00 |     | 1/2-13 X 1 1/2 SHCS                                  |              | in.         |
| 3    | opt | 025-0000-0262-02 | G   | FLASH 48 Interchangeable Load Cell - 1,000 lb        |              | in.         |
| 3    | opt | 025-0000-0262-14 | G   | FLASH 48 Interchangeable Load Cell - 1,000 lb w/o    |              | in.         |
| 3    | opt | 025-0000-0262-01 | G   | FLASH 48 Interchangeable Load Cell - 2,000 lb        |              | in.         |
| 3    | opt | 025-0000-0262-15 | G   | FLASH 48 Interchangeable Load Cell - 2,000 lb w/o    |              | in.         |
| 3    | opt | 025-0000-0262-00 | G   | FLASH 48 Interchangeable Load Cell - 3,000 lb        |              | in.         |
| 3    | opt | 025-0000-0262-10 | G   | FLASH 48 Interchangeable Load Cell - 3,000 lb w/o    |              | in.         |
| 3    | opt | 025-0000-0262-06 | G   | FLASH 48 Interchangeable Load Cell - 6,000 lb        |              | in.         |
| 3    | opt | 025-0000-0262-11 | G   | FLASH 48 Interchangeable Load Cell - 6,000 lb w/o    |              | in.         |
| 4    | 1   | 025-0000-0431-13 | A   | FLASH - Robostar attached head                       |              | in.         |
| 5    | 4   | 013-0000-0069-00 |     | 5/16-18 X 1 3/4 SHCS                                 |              | in.         |
| 6    | 1   | 025-0000-0918-01 | A   | Drive, FLASH 24 & 48, 6,000lb                        |              | in.         |
| 7    | 14  | 013-0000-0245-00 |     | 3/8-16 X 3/4 SHCS                                    |              | in.         |
| 8    | 14  | 013-2000-0100-00 |     | 3/8" FLAT WASHERS                                    |              | in.         |
| 9    | 1   | 025-0000-0755-01 |     | Lower Assembly - FLASH 48                            |              | in.         |
| 10   | 1   | 025-1000-0656-01 | A   | FLASH 48 6 amp drive, Up to 6,000 lb. Electronics    |              | in.         |
| 11   | opt | 018-0000-2029-00 | B   | 2" Platform, 5/8-18 to 5/16-18 Adapter               |              | in.         |
| 12   | opt | 025-0000-0814-00 | A   | 2 lb Quick Change Smart Interchangeable load cell    |              | in.         |
| 12   | opt | 025-0000-0814-01 | A   | 11 lb Quick Change Smart Interchangeable load cell   |              | in.         |
| 12   | opt | 025-0000-0814-02 | A   | 22 lb Quick Change Smart Interchangeable load cell   |              | in.         |
| 12   | opt | 025-0000-0814-03 | A   | 66 lb Quick Change Smart Interchangeable load cell   |              | in.         |
| 12   | opt | 025-0000-0814-04 | A   | 110 lb Quick Change Smart Interchangeable load cell  |              | in.         |
| 12   | opt | 025-0000-0814-05 | A   | 200 lb Quick Change Smart Interchangeable load cell  |              | in.         |
| 12   | opt | 025-0000-0814-06 | A   | 550 lb Quick Change Smart Interchangeable load cell  |              | in.         |
| 12   | opt | 025-0000-0814-07 | A   | 1000 lb Quick Change Smart Interchangeable load cell |              | in.         |
| 12   | opt | 025-0000-0814-08 | A   | 550 lb 6.0 dia Quick Change Smart Interchangeable    |              | in.         |
| 12   | opt | 025-0000-0814-09 | A   | 750 lb 6.0 dia Quick Change Smart Interchangeable    |              | in.         |
| 12   | opt | 025-0000-0814-10 | A   | 1000 lb 6.0 dia Quick Change Smart Interchangeable   |              | in.         |
| 12   | opt | 025-0000-0814-11 | A   | 1500 lb 6.0 dia Quick Change Smart Interchangeable   |              | in.         |

Approved by: \_\_\_\_\_

Date: \_\_\_\_\_

**SEE ATTACHED 3 DRAWINGS**



**025-0000-0920-00 A**  
**FLASH 48 - 6,000**

# Parts List

| Rev | By  | Date       | Description                                      |
|-----|-----|------------|--|
|     | RRS | 07-01-2013 |  |
| A   | RRS | 09-13-2013 | Item 7 was 013-0000-0167-00, is 013-0000-0245-00 |
|     |     |            |  |
|     |     |            |  |

| Item | Qty | Part Number      | Rev | Part Name  | PCB Location | Part Length |
|------|-----|------------------|-----|--|--------------|-------------|
| 12   | opt | 025-0000-0814-12 | A   | 2000 lb 6.0 dia Quick Change Smart Interchangeable |              | in.         |
| 13   | opt | 025-0000-0815-01 | C   | Quick Change Base Assembly, Interchangeable load   |              | in.         |
| 14   | ref | 025-2000-0165-07 | E   | Schematic, Flash 25-X000, Attached computer 240    |              | in.         |

Approved by: \_\_\_\_\_

Date: \_\_\_\_\_

**SEE ATTACHED 3 DRAWINGS**



**025-0000-0920-01 A**  
FLASH 48 - 13,200

# Parts List

| Rev | By  | Date       | Description                                      |
|-----|-----|------------|--|
|     | RRS | 07-01-2013 |  |
| A   | RRS | 09-13-2013 | Item 7 was 013-0000-0167-00, is 013-0000-0245-00 |
|     |     |            |  |
|     |     |            |  |

| Item | Qty | Part Number      | Rev | Part Name  | PCB Location | Part Length |
|------|-----|------------------|-----|--|--------------|-------------|
| 1    | 1   | 025-0000-0921-00 | A   | Upper Assembly, FLASH 48                             |              | in.         |
| 2    | 4   | 013-0000-0225-00 |     | 1/2-13 X 1 1/2 SHCS                                  |              | in.         |
| 3    | opt | 025-0000-0262-02 | G   | FLASH 48 Interchangeable Load Cell - 1,000 lb        |              | in.         |
| 3    | opt | 025-0000-0262-14 | G   | FLASH 48 Interchangeable Load Cell - 1,000 lb w/o    |              | in.         |
| 3    | opt | 025-0000-0262-01 | G   | FLASH 48 Interchangeable Load Cell - 2,000 lb        |              | in.         |
| 3    | opt | 025-0000-0262-15 | G   | FLASH 48 Interchangeable Load Cell - 2,000 lb w/o    |              | in.         |
| 3    | opt | 025-0000-0262-00 | G   | FLASH 48 Interchangeable Load Cell - 3,000 lb        |              | in.         |
| 3    | opt | 025-0000-0262-10 | G   | FLASH 48 Interchangeable Load Cell - 3,000 lb w/o    |              | in.         |
| 3    | opt | 025-0000-0262-06 | G   | FLASH 48 Interchangeable Load Cell - 6,000 lb        |              | in.         |
| 3    | opt | 025-0000-0262-11 | G   | FLASH 48 Interchangeable Load Cell - 6,000 lb w/o    |              | in.         |
| 3    | opt | 025-0000-0262-07 | G   | FLASH 48 Interchangeable Load Cell - 10,000 lb       |              | in.         |
| 3    | opt | 025-0000-0262-12 | G   | FLASH 48 Interchangeable Load Cell - 10,000 lb w/o   |              | in.         |
| 3    | opt | 025-0000-0262-08 | G   | FLASH 48 Interchangeable Load Cell - 13,200 lb       |              | in.         |
| 3    | opt | 025-0000-0262-13 | G   | FLASH 48 Interchangeable Load Cell - 13,200 lb w/o   |              | in.         |
| 4    | 1   | 025-0000-0431-13 | A   | FLASH - Robostar attached head                       |              | in.         |
| 5    | 4   | 013-0000-0069-00 |     | 5/16-18 X 1 3/4 SHCS                                 |              | in.         |
| 6    | 1   | 025-0000-0918-00 | A   | Drive, FLASH 24 & 48, 12,000lb                       |              | in.         |
| 7    | 14  | 013-0000-0245-00 |     | 3/8-16 X 3/4 SHCS                                    |              | in.         |
| 8    | 14  | 013-2000-0100-00 |     | 3/8" FLAT WASHERS                                    |              | in.         |
| 9    | 1   | 025-0000-0755-01 |     | Lower Assembly - FLASH 48                            |              | in.         |
| 10   | 1   | 025-1000-0656-00 | A   | FLASH 48 3-Phase 12 amp drive, 15,000 lb Electronics |              | in.         |
| 11   | opt | 018-0000-2029-00 | B   | 2" Platform, 5/8-18 to 5/16-18 Adapter               |              | in.         |
| 12   | opt | 025-0000-0814-00 | A   | 2 lb Quick Change Smart Interchangeable load cell    |              | in.         |
| 12   | opt | 025-0000-0814-01 | A   | 11 lb Quick Change Smart Interchangeable load cell   |              | in.         |
| 12   | opt | 025-0000-0814-02 | A   | 22 lb Quick Change Smart Interchangeable load cell   |              | in.         |
| 12   | opt | 025-0000-0814-03 | A   | 66 lb Quick Change Smart Interchangeable load cell   |              | in.         |
| 12   | opt | 025-0000-0814-04 | A   | 110 lb Quick Change Smart Interchangeable load cell  |              | in.         |
| 12   | opt | 025-0000-0814-05 | A   | 200 lb Quick Change Smart Interchangeable load cell  |              | in.         |
| 12   | opt | 025-0000-0814-06 | A   | 550 lb Quick Change Smart Interchangeable load cell  |              | in.         |
| 12   | opt | 025-0000-0814-07 | A   | 1000 lb Quick Change Smart Interchangeable load cell |              | in.         |

Approved by: \_\_\_\_\_

Date: \_\_\_\_\_

**SEE ATTACHED 3 DRAWINGS**



**025-0000-0920-01 A**  
FLASH 48 - 13,200

# Parts List

| Rev | By  | Date       | Description                                      |
|-----|-----|------------|--|
|     | RRS | 07-01-2013 |  |
| A   | RRS | 09-13-2013 | Item 7 was 013-0000-0167-00, is 013-0000-0245-00 |
|     |     |            |  |
|     |     |            |  |

| Item | Qty | Part Number      | Rev | Part Name  | PCB Location | Part Length |
|------|-----|------------------|-----|--|--------------|-------------|
| 12   | opt | 025-0000-0814-08 | A   | 550 lb 6.0 dia Quick Change Smart Interchangeable    |              | in.         |
| 12   | opt | 025-0000-0814-09 | A   | 750 lb 6.0 dia Quick Change Smart Interchangeable    |              | in.         |
| 12   | opt | 025-0000-0814-10 | A   | 1000 lb 6.0 dia Quick Change Smart Interchangeable   |              | in.         |
| 12   | opt | 025-0000-0814-11 | A   | 1500 lb 6.0 dia Quick Change Smart Interchangeable   |              | in.         |
| 12   | opt | 025-0000-0814-12 | A   | 2000 lb 6.0 dia Quick Change Smart Interchangeable   |              | in.         |
| 13   | opt | 025-0000-0815-01 | C   | Quick Change Base Assembly, Interchangeable load     |              | in.         |
| 14   | ref | 025-2000-0165-13 |     | Schematic, Flash 48 -15,000, Att. comp. 240VAC 3 Ph. |              | in.         |

Approved by: \_\_\_\_\_

Date: \_\_\_\_\_

**SEE ATTACHED 3 DRAWINGS**



| REV | DATE | DESCRIPTION | DRW | APP |
|-----|------|-------------|-----|-----|
|     |      | SEE SHEET 4 |     |     |

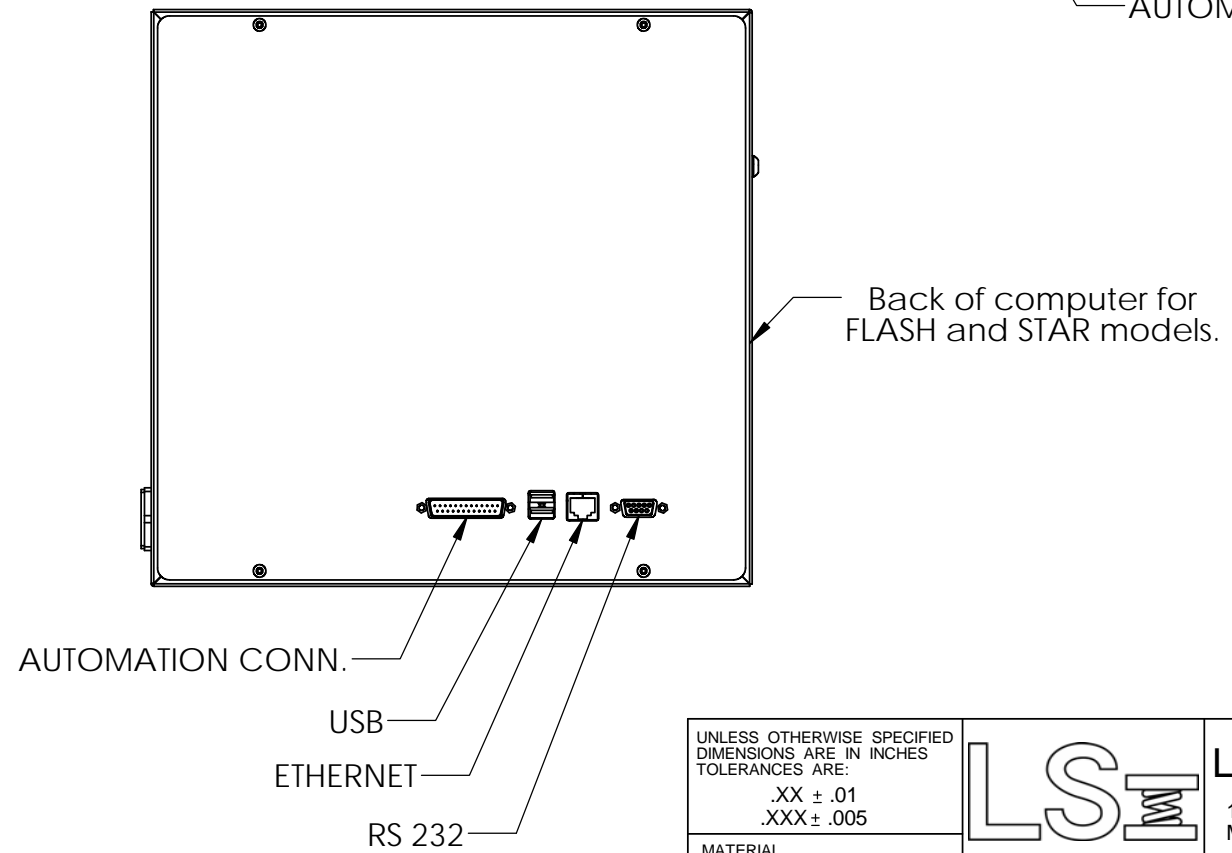
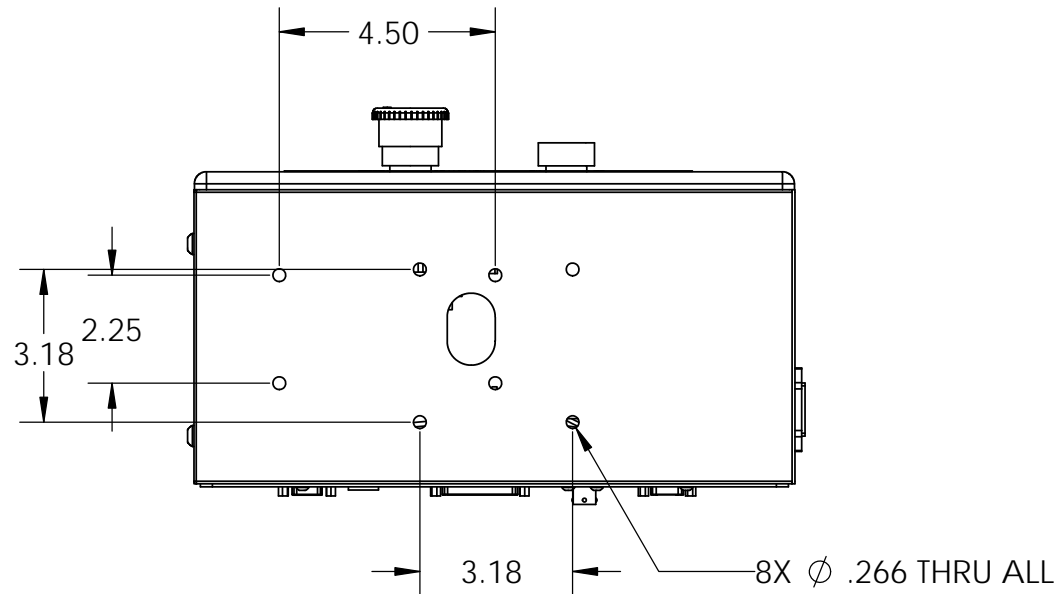
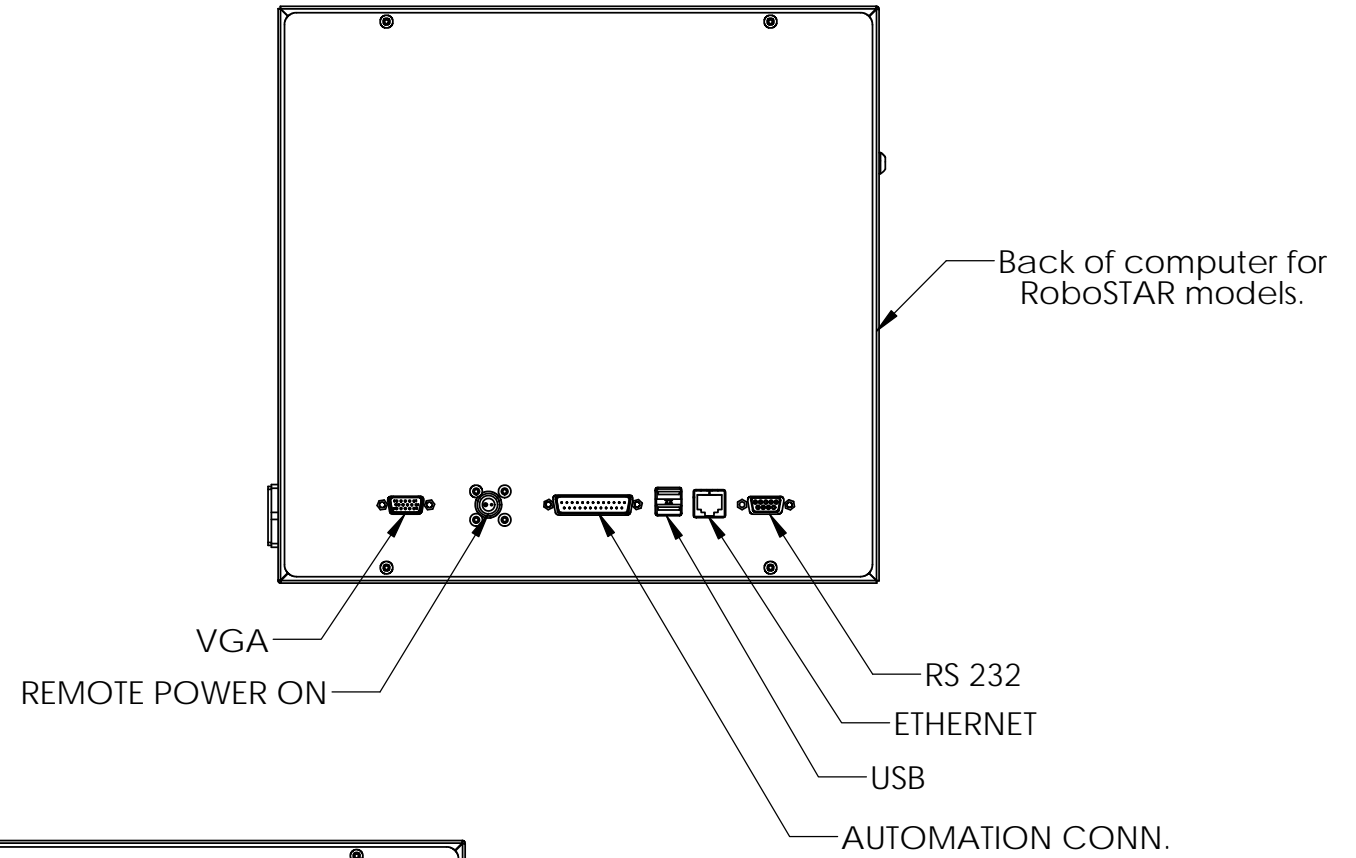
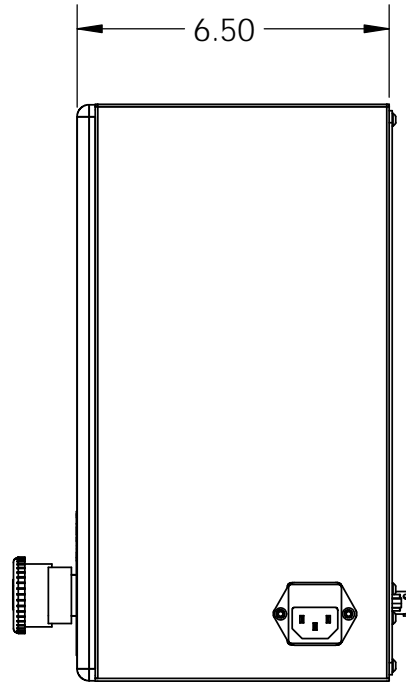
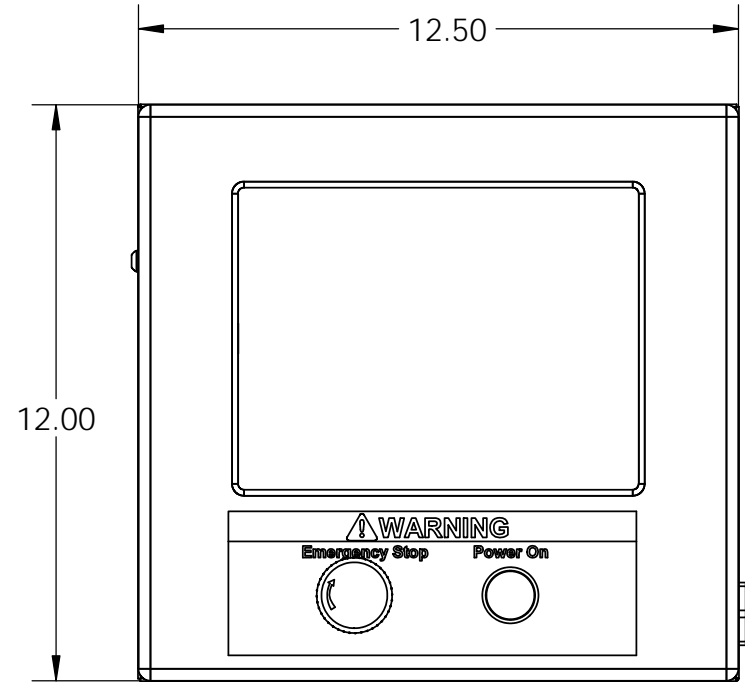

|   |            |        |  |  |
|---|------------|--------|--|--|
| UNLESS OTHERWISE SPECIFIED DIMENSIONS ARE IN INCHES TOLERANCES ARE:<br>.XX ± .01<br>.XXX ± .005 | <b>LSI</b> |        | <b>LARSON SYSTEMS INC.</b>   |  |
|   |            |        | 10073 Baltimore St. NE PH. 763-780-2131<br>Mpls., MN 55449 FAX. 763-780-2182 |  |
| MATERIAL See Parts List   | APPROVALS  | DATE   | FLASH COMPUTER ASSEMBLY  |  |
| FINISH -  | DRAWN KMP  | 7-6-06 | B DWG. NO. 025-0000-0431-10C   |  |
| HEAT TREAT  | APP.       |        | SCALE: NONE SHEET 1 OF 5   |  |

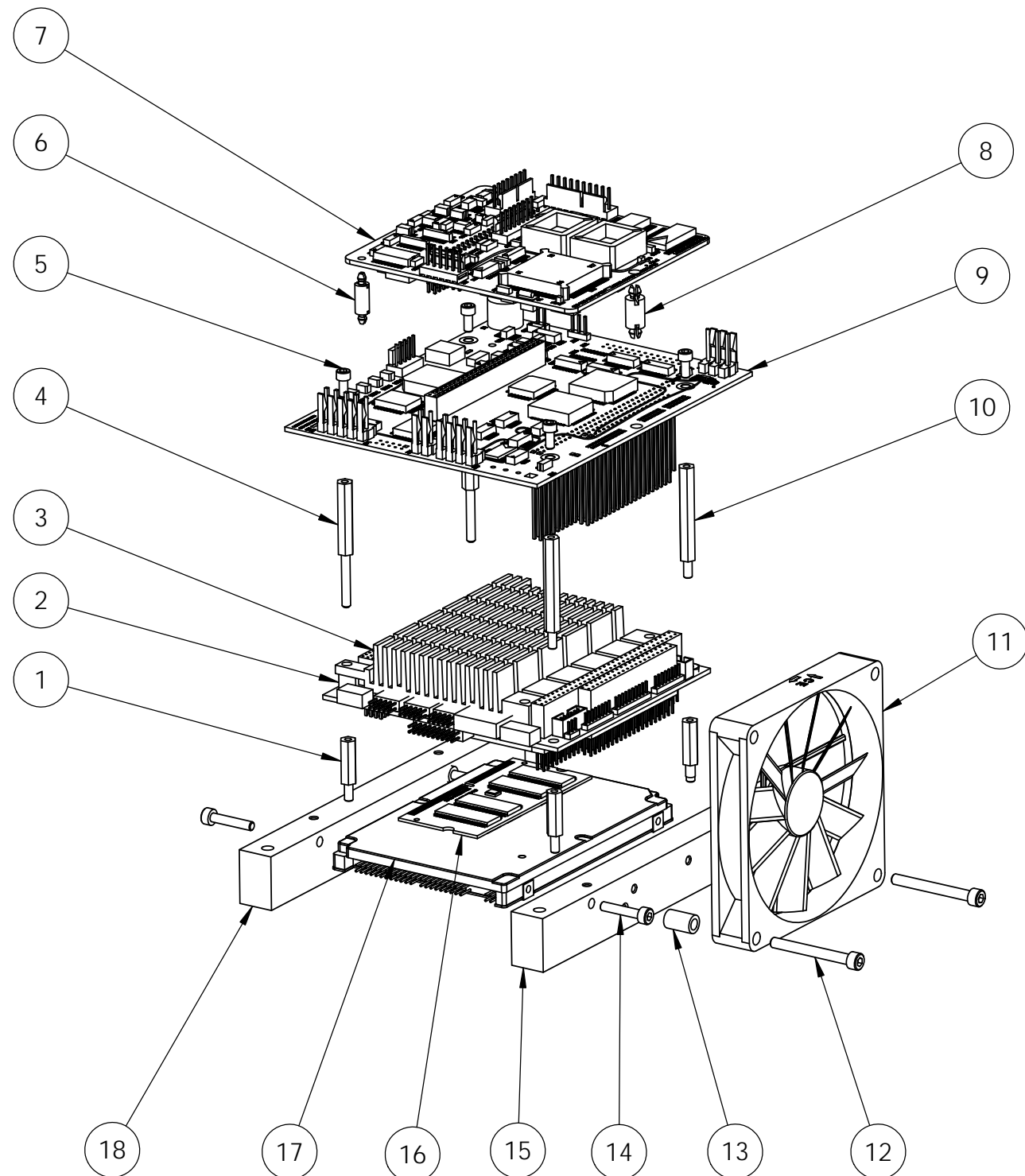

- NOTES:
- NOTE ORIENTATION OF ITEMS 14, 15, & 18
  - INSTALL ITEM 16 TO ITEM 3 BEFORE ATTACHING TO ITEM 1
  - NOTE ORIENTATION OF ITEM 3
  - PLUG IN CABLES TO ITEM 3 (PC 104 MODULE) PER SCHEMATIC 025-2000-0165-XX
  - NOTE ORIENTATION OF ITEMS 7 & 9
  - INSTALL ITEMS 6, 7, 8, & 9 BEFORE ATTACHING TO ITEM 3
  - NOTE ORIENTATION OF ARROW ON ITEM 11 TO BE POINTING TOWARD ASSEMBLY BEFORE MOUNTING TO ITEM 15.

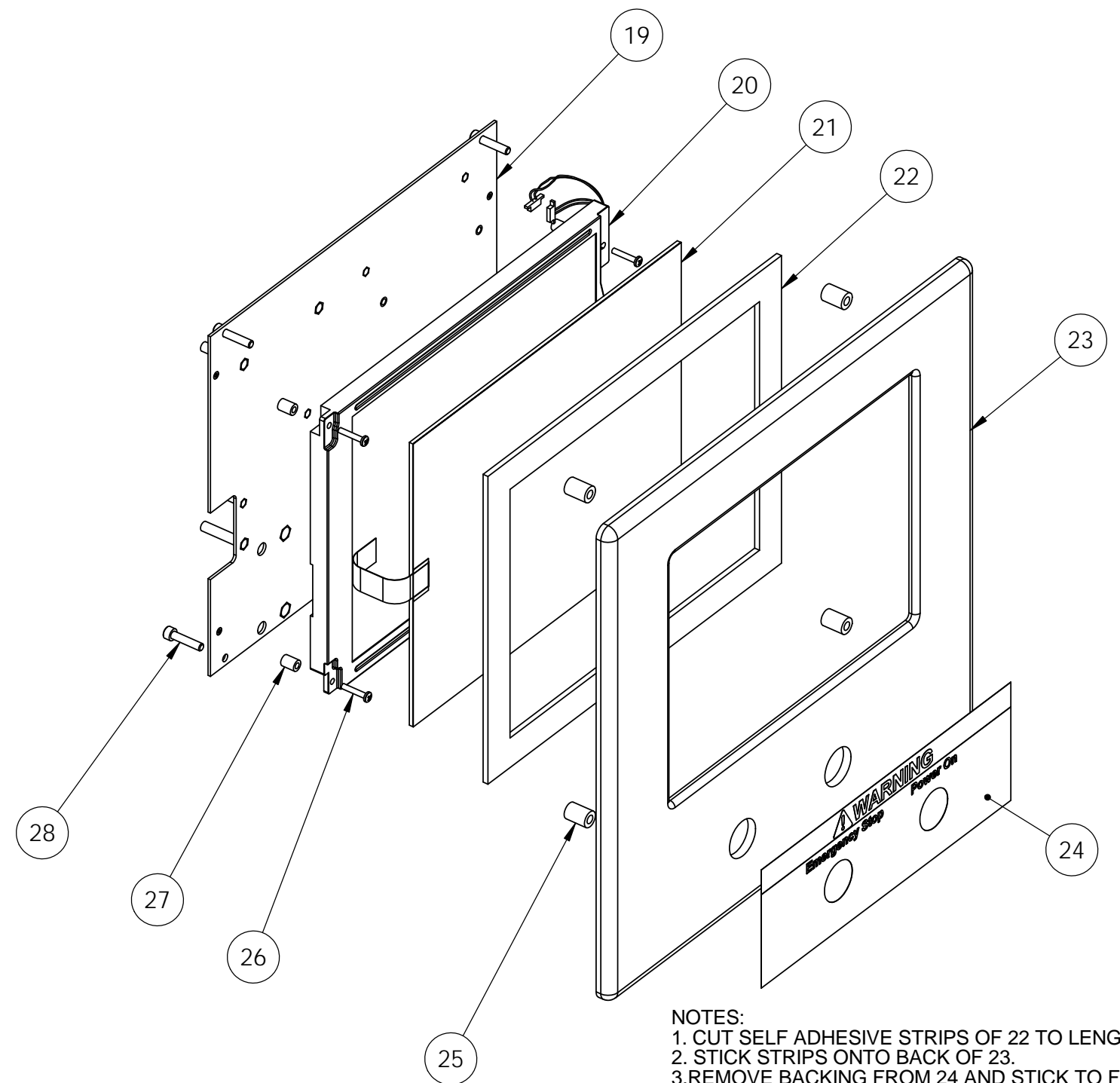

- NOTES:
- CUT SELF ADHESIVE STRIPS OF 22 TO LENGTH.
  - STICK STRIPS ONTO BACK OF 23.
  - REMOVE BACKING FROM 24 AND STICK TO FRONT OF 23.
  - NOTE ORIENTATION OF ITEMS 19 & 20
  - INSTALL ITEM 19 TO 20 USING ITEM 26 (4X) & ITEM 27 (4X) BEFORE ATTACHING TO ITEM 23.
  - NOTE ORIENTATION OF ITEMS 21 & 23
  - ALIGN ITEM 21 & 23 SO THAT THE ACTIVE AREA OF TOUCHSCREEN IS CENTERED ON THE OPEN AREA OF ITEM 23 (FRONT BEZEL). PEEL & PREPARE FRONT AND BACK ADHESIVE OF TOUCHSCREEN AND PLACE IT.
  - INSTALL ITEM 19 TO ITEM 23 USING ITEM 25 AND ITEM 28.

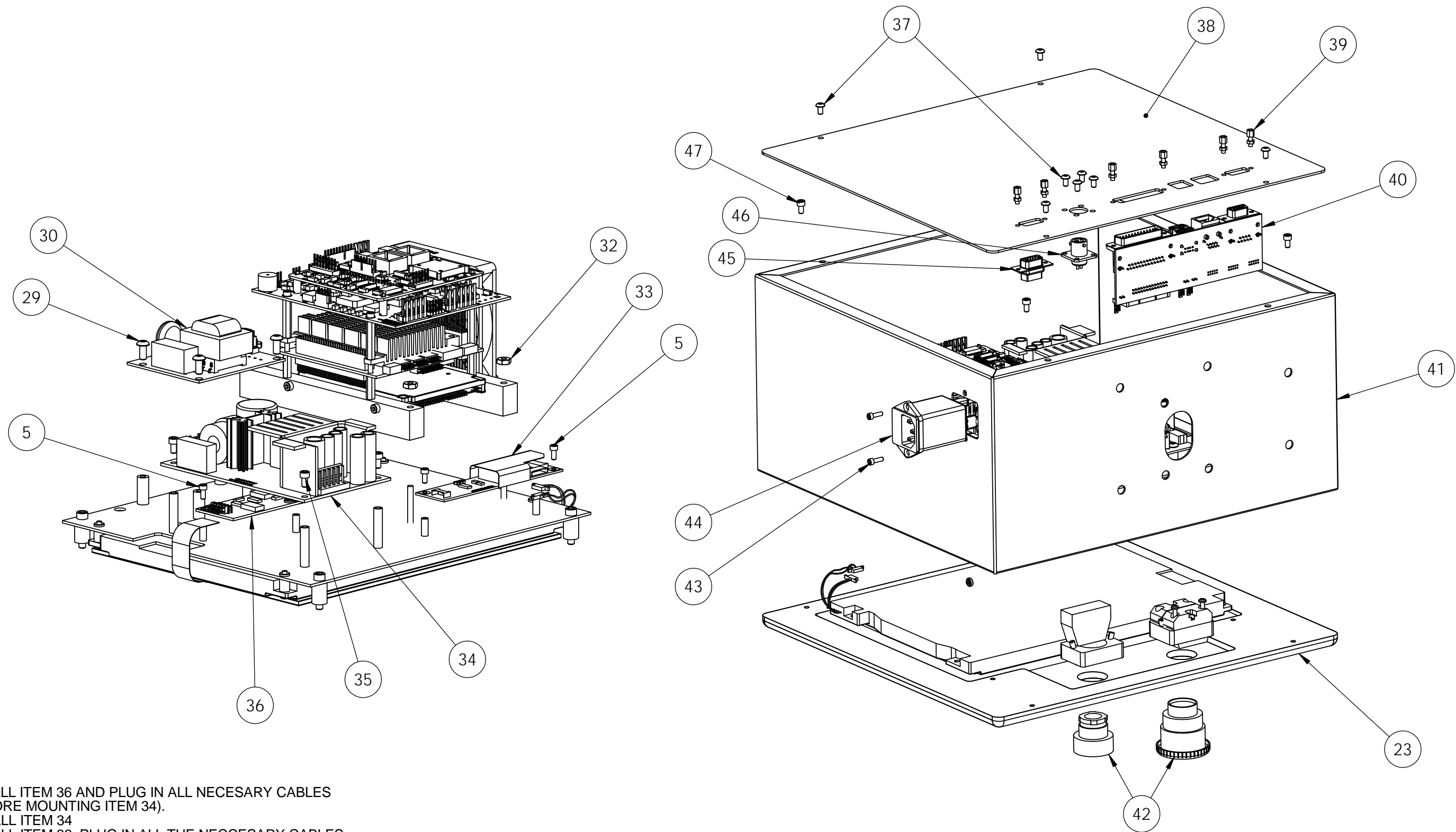

NOTES:

1. INSTALL ITEM 36 AND PLUG IN ALL NECESSARY CABLES (BEFORE MOUNTING ITEM 34).
2. INSTALL ITEM 34
3. INSTALL ITEM 33. PLUG IN ALL THE NECESSARY CABLES
4. PLUG IN ALL CABLES TO ITEM 31 (EXTERNAL CONNECTORS ASSEMBLY) AND ALL REMAINING CABLES PER SCHEMATIC 025-2000-0165-XX

**5. HAVE ASSEMBLY CHECKED BEFORE NEXT OPERATION.**

6. APPLY LOCTITE 242 BLUE TO ITEMS 47 AT THE END OF ASSEMBLY.
7. **FOR 230V MODEL,** BOTH JUMPERS FROM ITEM 30 "AC DISTRIBUTION PC ASSEMBLY" NEED TO BE REMOVED AND ONE JUMPER NEEDS TO BE PLACED ON PINS 2 AND 3

NOTES:

1. INSTALL ITEMS 42 TO ITEM 23
2. INSTALL ITEM 41 TO BACK OF BEZEL USING ITEM 35 (4X) BEFORE ATTACHING ITEMS 39 & 40



**025-0000-0431-10 C**  
FLASH - Computer Assembly

# Parts List

| Rev | By  | Date       | Description   |
|-----|-----|------------|---|
|     | KMP | 07-05-2006 |   |
| A   | DAL | 08-03-2007 | Added 060-4000-0202-00 factory setup and startup instructions Add Item 21   |
| B   | EJS | 05-23-2008 | REMOVED ITEMS 45, 46. (WAS 25-1-501-02 & 25-1-502-02) REPLACE WITH ITEM 45, THE WHOLE SWITCH ASSEMBLY   |
| C   | RRS | 03-23-2012 | Removed 47, 48 added Robostar config., combined e-stop and on switch into one assembly. renumbered 42 through 47. Removed special notes and added notes concerning location and numbers for the 230V models |

| Item | Qty | Part Number      | Rev | Part Name                                    | PCB Location | Part Length |
|------|-----|------------------|-----|--|--------------|-------------|
| 1    | 4   | 018-0000-2479-00 | A   | 4-40 male - female standoff                  |              | in.         |
| 2    | 2   | 018-0000-3205-00 |     | Spacer For Flash PC104 Module                |              | in.         |
| 3    | 1   | 016-2000-0012-00 | B   | PC104 (Pentium) for FLASH Systems            |              | in.         |
| 4    | 2   | 018-0000-2802-00 | A   | Standoff Hex, 4-40 X 1.00 M-F                |              | in.         |
| 5    | 8   | 013-0000-0178-00 |     | 4-40 X 1/4 SHCS                              |              | in.         |
| 6    | 2   | 018-0000-2680-00 | A   | Standoff Double Snap-in (.100 Dia Hole)      |              | in.         |
| 7    | 1   | 025-1000-0299-01 | N   | SDHT 3 Analog / Digital PCB Assembly - FLASH |              | in.         |
| 8    | 1   | 018-0000-2682-00 | C   | Standoff Double Snap-in (.152 Dia Hole)      |              | in.         |
| 9    | 1   | 025-1000-0359-01 | F   | FLASH PC104 Adapter (Pentium)                |              | in.         |
| 10   | 2   | 018-0000-2801-00 | A   | Standoff Hex, 4-40 X 1.353 M-F               |              | in.         |
| 11   | 1   | 025-1000-0413-01 | C   | Fan Assembly, FLASH (Pentium)                |              | in.         |
| 12   | 2   | 013-0000-0470-00 |     | 6-32 X 1 1/4 SHCS                            |              | in.         |
| 13   | 2   | 018-0000-2672-00 |     | Spacer, .250 Dia, Flash                      |              | in.         |
| 14   | 4   | 013-0000-0188-00 |     | M3-0.5 X 16 mm SHCS                          |              | in.         |
| 15   | 1   | 018-0000-2478-01 | C   | FLASH PC 104 Module Mounting Bar, Left       |              | in.         |
| 16   | 1   | 016-2000-0013-00 |     | 1GB Kingston 667 MHz DDR2 SODIMM Memory      |              | in.         |
| 17   | 1   | 016-2000-0006-00 | B   | 2.5" SATA Notebook Hard Drive                |              | in.         |
| 18   | 1   | 018-0000-2478-00 | C   | FLASH PC104 Module Mounting Bar, Right       |              | in.         |
| 19   | 1   | 018-0000-2411-00 | G   | LCD Mounting Plate                           |              | in.         |
| 20   | 1   | 014-4000-0006-00 |     | LCD for FLASH Systems                        |              | in.         |
| 21   | 1   | 014-4000-0008-00 | B   | Touchscreen for FLASH Systems                |              | in.         |
| 22   | 4   | 010-3000-0035-00 |     | 3/4" Vinyl Foam Tape                         |              | in.         |
| 23   | 1   | 018-0000-2862-00 | A   | Computer Front Bezel, Flash                  |              | in.         |
| 24   | 1   | 017-0000-0029-02 | B   | Emergency Stop / Power On / Warning Label    |              | in.         |
| 25   | 4   | 018-0000-2674-00 |     | Spacer BEZEL, Flash                          |              | in.         |
| 26   | 4   | 013-0000-0163-00 |     | 4-40 X 5/8 PHMSPH                            |              | in.         |
| 27   | 4   | 018-0000-2475-00 |     | .250 x .334 Display Spacer ID .134, Flash    |              | in.         |
| 28   | 4   | 013-0000-0156-00 |     | 8-32 X 3/4 SHCS                              |              | in.         |
| 29   | 4   | 013-0000-0012-00 |     | 8-32 X 3/8 Button Head Cap Screw             |              | in.         |
| 30   | 1   | 025-1000-0583-00 |     | Flash AC Distribution PCB Assembly           |              | in.         |

Approved by: 

Date: April 26, 2012

**SEE ATTACHED 3 DRAWINGS**



**025-0000-0431-10 C**  
**FLASH - Computer Assembly**

# Parts List

| Rev | By  | Date       | Description   |
|-----|-----|------------|---|
|     | KMP | 07-05-2006 |   |
| A   | DAL | 08-03-2007 | Added 060-4000-0202-00 factory setup and startup instructions Add Item 21   |
| B   | EJS | 05-23-2008 | REMOVED ITEMS 45, 46. (WAS 25-1-501-02 & 25-1-502-02) REPLACE WITH ITEM 45, THE WHOLE SWITCH ASSEMBLY   |
| C   | RRS | 03-23-2012 | Removed 47, 48 added Robostar config., combined e-stop and on switch into one assembly. renumbered 42 through 47. Removed special notes and added notes concerning location and jumpers for the 230V models |

| Item | Qty | Part Number      | Rev | Part Name  | PCB Location | Part Length |
|------|-----|------------------|-----|--|--------------|-------------|
| 32   | 4   | 013-0000-0002-00 |     | 6-32 Hex Nut                                     |              | in.         |
| 33   | 1   | 014-4000-0007-00 | A   | Backlight Inverter PCB assembly                  |              | in.         |
| 34   | 1   | 011-0000-0022-00 | A   | 5V / 12V DC SUPPLY FOR FLASH                     |              | in.         |
| 35   | 4   | 013-0000-0142-00 |     | 6-32 X 1/4 SHCS                                  |              | in.         |
| 36   | 1   | 014-4000-0009-00 | A   | TOUCHSCREEN INTERFACE PCB                        |              | in.         |
| 37   | 8   | 013-0000-0077-00 |     | 6-32 X 1/4 BHCS                                  |              | in.         |
| 38   | 1   | 018-0000-2864-00 | B   | Computer Back Cover, FLASH / Star                |              | in.         |
| 38   | Ref | 018-0000-2864-02 | B   | Computer Back Cover, FLASH / RoboStar, with VGA  |              | in.         |
| 39   | 6   | 013-1000-0010-00 |     | Female Screw Lock                                |              | in.         |
| 40   | 1   | 025-1000-0393-00 | A   | FLASH External Connectors Assembly               |              | in.         |
| 41   | 1   | 018-0000-2863-00 |     | Flash Computer Enclosure                         |              | in.         |
| 42   | 1   | 025-1000-0585-00 |     | Cable, Flash AC Dist pcb to Start/Epo switches   |              | in.         |
| 43   | 2   | 013-0000-0010-00 |     | 4-40 X 3/8 SHCS                                  |              | in.         |
| 44   | 1   | 025-1000-0500-00 | D   | Power Entry 120V Cable, Flash                    |              | in.         |
| 44   | Ref | 025-1000-0500-01 | D   | Power Entry 230V Cable, Flash                    |              | in.         |
| 45   | Ref | 025-1000-0641-01 |     | VGA Cable for FLASH Computers - Extended         |              | in.         |
| 46   | Ref | 025-1000-0585-01 |     | Cable, Flash AC Dist pcb to Start/Epo switches & |              | in.         |
| 47   | 4   | 013-0000-0139-00 |     | 8-32 X 1/4 SHCS                                  |              | in.         |
| 50   | Ref | 060-4000-0202-00 | E   | Procedure : FLASH Tester Computer Assembly       |              | in.         |
| 51   | 1   | 016-2000-0014-00 | A   | Windows 7 Pro OEM Install DVD                    |              | in.         |

Approved by: 

Date: April 26, 2012

**SEE ATTACHED 3 DRAWINGS**



**Larson Systems Inc.**  
10073 Baltimore Street NE  
Minneapolis, MN 55449-4425  
[www.larsonsystems.com](http://www.larsonsystems.com)

763-780-2131  
1-877-780-2131  
Fax: 763-780-2182  
[info@larsonsystems.com](mailto:info@larsonsystems.com)

