

Larson Systems Inc.

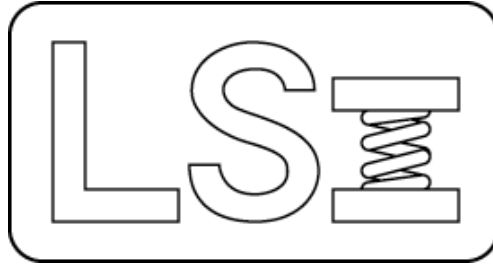

DHT 1500 Parts List

050-0000-0101-01

Digital Hand Tester





050-0000-0101-01 B

Parts List

DHT 1500 - 750 lb Capacity, Lever Operated

Rev	By	Date	Description
	KMP	03-11-2004	
A	MDL	09-24-2004	Added sticker assembly.
B	DAL	09-07-2007	060-1000-0025-00 was 060-1000-0079-00



Item	Qty	Part Number	Rev	Part Name	PCB Location	Part Length
1	1	025-0000-0435-00	M	SDHT 2000 / DHT 1500 Assembly		in.
2	1	025-0000-0342-04	A	Force Meter - DHT 1500 / DHT Carlson Upgrade		in.
3	1	050-1000-0010-00	Q	DHT Software Version 7.1		in.
4	1	060-1000-0025-00	K	User Manual - ECT / CDHT / FDHT / DHT / CST		in.
5	1	060-2000-0027-00		Parts List - DHT 1500		in.
6	1	059-0000-0043-00	A	Shipping Crate - SDHT 2000 / CST, 18" range rods		in.
6		059-0000-0043-01	A	Shipping Crate - SDHT 2000, 24" range rods		in.
6		059-0000-0043-02	A	Shipping Crate - SDHT 2000, 36" range rods		in.
6		059-0000-0043-03	A	Shipping Crate - SDHT 2000, 48" range rods		in.
7	1	025-6000-0026-00		Sticker Assembly - DHT 1500		in.

Approved by: 

Date: September 7, 2007

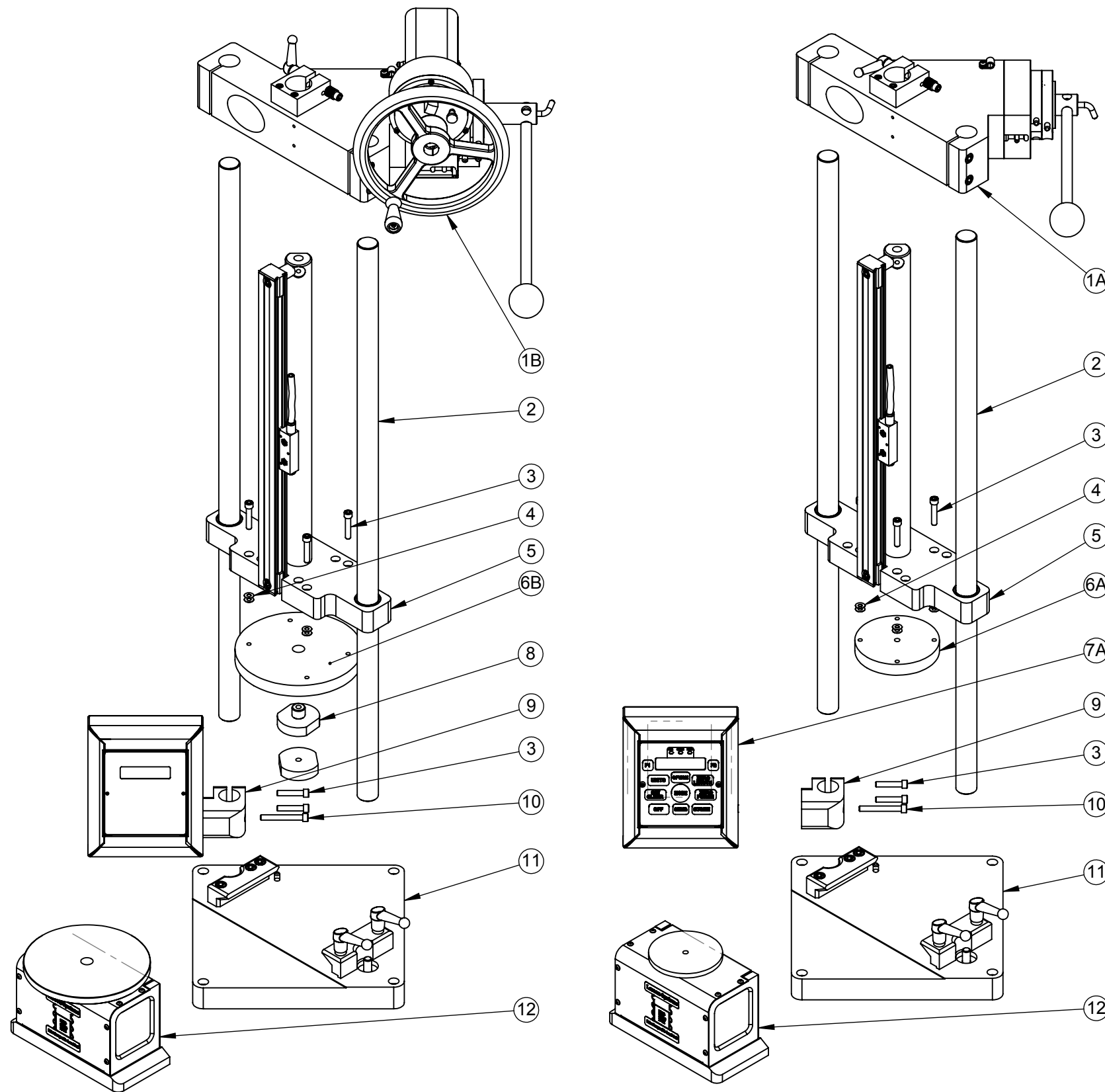
REV	DATE	DESCRIPTION	DRW	APP
		SEE SHEET 2		

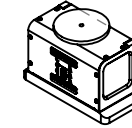

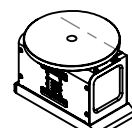
Options with the Lever Operated Assembly and the Micro Adjust Assembly							
Platform Dia.	ITEM 6		Load Cell Cap.	ITEM 12			
	4"	018-0000-2028-00		2 lb	025-0000-0814-00		
	4"	018-0000-2028-00		11 lb	025-0000-0814-01		
	4"	018-0000-2028-00		22 lb	025-0000-0814-02		
	4"	018-0000-2028-00		66 lb	025-0000-0814-03		
	4"	018-0000-2028-00		110 lb	025-0000-0814-04		
	4"	018-0000-2028-00		200 lb	025-0000-0814-05		
	6"	018-0000-2038-00		550 lb	025-0000-0814-08		
	6"	018-0000-2038-00		750 lb	025-0000-0814-09		
	<u>Optional with the</u>				<u>Micro Adjust Assembly Only</u>		
	6"	018-0000-2038-00			1000 lb	025-0000-0814-10	
	6"	018-0000-2038-00			1500 lb	025-0000-0814-11	
	6"	018-0000-2038-00			2000 lb	025-0000-0814-12	

Item 8 018-0000-2029-00
 2" dia platform and 5/8-18 to 5/16-18 thd adapter is only supplied in multiple load cell systems when 3.5" dia platform load cells (025-0000-0814-00 to -05) are purchased as well as 6" dia platform load cells 025-0000-0814-08 to -12). Also supply 6" dia platform 018-0000-2038-00.

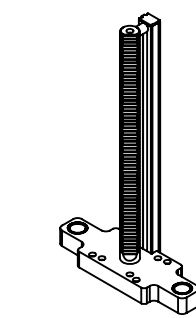

Stroke Length	Thru Hole Dia.	Item 5
13 Inch (Standard)	Ø.437	025-0000-0446-00
18 Inch	Ø.437	025-0000-0446-03
24 Inch	Ø.437	025-0000-0446-04
18 Inch	NONE	025-0000-0446-01
24 Inch	NONE	025-0000-0446-02
36 Inch	NONE	025-0000-0446-05

Extended Range Rod	Item 2
Standard 18 Inch	018-0000-1996-00
24 Inch	018-0000-1996-03
36 Inch	018-0000-1996-01
48 Inch	018-0000-1996-02
60 Inch	018-0000-1996-04
72 Inch	018-0000-1996-05

Force Meter	Item 7
SDHT	025-0000-0342-03
DHT	025-0000-0342-04

LS

=

M

LARSON SYSTEMS INC.
 10073 Baltimore St. NE PH. 763-780-2131
 Mpls., MN 55449 FAX. 763-780-2182

APPROVALS	DATE	SDHT 2000 / DHT 1500 Assembly
DRAWN KMP	2/25/04	
APP.		B DWG. NO. 025-0000-0435-00M
APP.		
SCALE: NONE		SHEET 1 OF 3



025-0000-0435-00 M
SDHT 2000 / DHT 1500 Assembly

Parts List

Rev	By	Date	Description
H	KMP	06-24-2005	Change Item 10 013-0-0032-00-013-0-0031-00, delete Items 24, 25, 26.
J	KMP	03-23-2007	Change Linear Encoder Mounting, Change Item 3 was 014-1-0015-01, Item 6 was 018-0-1991-00, Item 7 was 013-0-0181-00, Item 9 was 013-0-0064-00, Item 10 was /2/, Item 18 was 013-0-0323-00, Delete Items 4
K	KMP	07-20-2007	Change Item 2 to rods only, Change Items 3, 6, 10, 18 to Ref. Added Load Cell No. 025-0-0433-04 (2,000 lb) to Item 23
M	DAL	01-08-2013	redesign to use 025-0000-0814-XX load cells

Item	Qty	Part Number	Rev	Part Name	PCB Location	Part Length
1A	1	025-0000-0434-01	A	Lever Operated Assembly SDHT 2000 - 750		in.
1B	Opt	025-0000-0434-00	J	Micro Length Adjust Assembly (2000 lb Capacity)		in.
2	2	018-0000-1996-00	E	32" Support Rods for 18" Range		in.
2	Opt	018-0000-1996-03	E	36" Support Rods for 24" Range		in.
2	Opt	018-0000-1996-01	E	48" Support Rods for 36" Range		in.
2	Opt	018-0000-1996-02	E	60" Support Rods for 48" Range		in.
2	Opt	018-0000-1996-04	E	72" Support Rods for 60" Range		in.
2	Opt	018-0000-1996-05	E	84" Support Rods for 72" range		in.
3	6	013-0000-0065-00		1/4-20 X 1 1/4 SHCS		in.
4	AR	018-0000-0435-02	C	Shim - 0.255 ID, 0.450 OD, 0.0010 thick		in.
5	1	025-0000-0446-00	G	Gear Rack Assembly - 13" Stroke (0.437" Thru-Hole)		in.
5	Opt	025-0000-0446-03	F	Gear Rack Assembly - 18" Stroke (0.437" Thru-Hole)		in.
5	Opt	025-0000-0446-04	F	Gear Rack Assembly - 24" Stroke (0.437" Thru-Hole)		in.
5	Opt	025-0000-0446-01	F	Gear Rack Assembly - 18" Stroke		in.
5	Opt	025-0000-0446-02	F	Gear Rack Assembly - 24" Stroke		in.
5	Opt	025-0000-0446-05	F	Gear Rack Assembly - 36" Stroke		in.
6A	Cht	018-0000-2028-00	C	4" Platform		in.
6B	Cht	018-0000-2038-00	A	6" Upper Platform SDHT 2000		in.
7A	Ref	025-0000-0342-03	A	Super Force Meter SDHT- 2000, SDHT Carlson		in.
7B	Ref	025-0000-0342-04	A	Force Meter - DHT 1500 / DHT Carlson Upgrade		in.
8	Cht	018-0000-2029-00	B	2" Platform, 5/8-18 to 5/16-18 Adapter		in.
9	1	018-0000-1716-00	J	Upgrade Meter Clamp		in.
10	1	013-0000-0254-00		1/4-20 X 2 SHCS		in.
11	1	025-0000-0905-00		Base Assembly, SDHT 2000 DHT 1500		in.
12	Opt	025-0000-0814-00	A	2 lb Quick Change Smart Interchangeable load cell		in.
12	Opt	025-0000-0814-01	A	11 lb Quick Change Smart Interchangeable load cell		in.
12	Opt	025-0000-0814-02	A	22 lb Quick Change Smart Interchangeable load cell		in.
12	Opt	025-0000-0814-03	A	66 lb Quick Change Smart Interchangeable load cell		in.
12	Opt	025-0000-0814-04	A	110 lb Quick Change Smart Interchangeable load cell		in.
12	Opt	025-0000-0814-05	A	200 lb Quick Change Smart Interchangeable load cell		in.

Approved by:

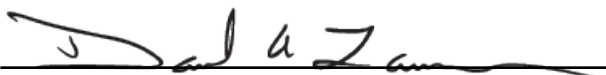

Date:

January 11, 2013

SEE ATTACHED DRAWING



025-0000-0435-00 M
SDHT 2000 / DHT 1500 Assembly

Parts List

Rev	By	Date	Description
H	KMP	06-24-2005	Change Item 10 013-0-0032-00-013-0-0031-00, delete Items 24, 25, 26.
J	KMP	03-23-2007	Change Linear Encoder Mounting, Change Item 3 was 014-1-0015-01, Item 6 was 018-0-1991-00, Item 7 was 013-0-0181-00, Item 9 was 013-0-0064-00, Item 10 was (?), Item 18 was 013-0-0323-00. Delete Items 4
K	KMP	07-20-2007	Change Item 2 to rods only, Change Items 3, 6, 10, 18 to Ref. Added Load Cell No. 025-0-0433-04 (2,000 lb) to Item 23
M	DAL	01-08-2013	redesign to use 025-0000-0814-XX load cells

Item	Qty	Part Number	Rev	Part Name	PCB Location	Part Length
12	Opt	025-0000-0814-08	A	550 lb 6.0 dia Quick Change Smart Interchangeable		in.
12	Opt	025-0000-0814-09	A	750 lb 6.0 dia Quick Change Smart Interchangeable		in.
12	Opt	025-0000-0814-10	A	1000 lb 6.0 dia Quick Change Smart Interchangeable		in.
12	Opt	025-0000-0814-11	A	1500 lb 6.0 dia Quick Change Smart Interchangeable		in.
12	Opt	025-0000-0814-12	A	2000 lb 6.0 dia Quick Change Smart Interchangeable		in.
13	1	025-6000-0006-00	D	Sticker Assembly - SDHT 2000		in.

Approved by: _____

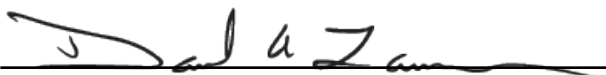

Date: _____

January 11, 2013

SEE ATTACHED DRAWING

REV	DATE	DESCRIPTION	DRW	APP
		SEE SHEET 2		

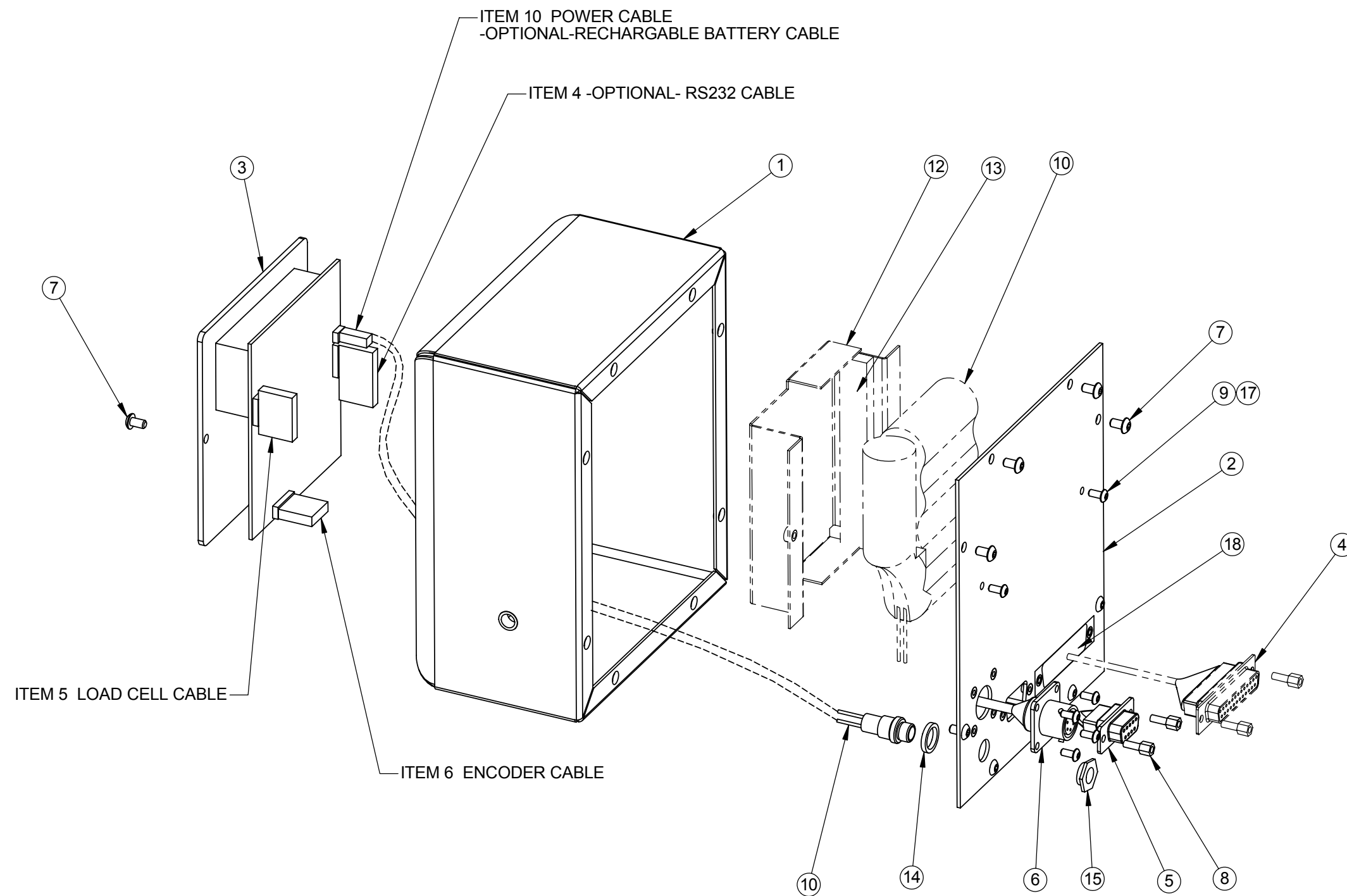

1. Assemble #14, Power Jack Spacer / Insulator on #10, Power Cable or Battery Connector, than insert thru #2 Cover and tighten with #15 Power Jack Nut.
2. Assemble #4, MTT RS 232 Cable, #5, Load Cell Cable with #8 Female Screw Locks and #6 Encoder Cable with (4) #9 4-40 X 1/4 BHSCS to the #2, Cover.
3. Optional Battery assembling- #14, Foam Tape on the inside of #11 Battery Retainer along one side and one end, assemble #11, Battery Retainer and #10 Rechargable Battery to #2 Cover with (2) #9 4-40 X 1/4 BHSCS.
4. Mount #2, Cover To the bottom of #1, Enclosure Force Meter with #7 6-32 X 1/4 BHSCS.
5. Install #6, Encorder Cable, #5, Load Cell Cable, #4 MTT RS 232 Cable and #10 Power Cable or Rechargable Battery cable to #3, Front Panel Assembly. Then set #1 Front Panel in place and screw #7 6-32 X 1/4 BHSCS.

UNLESS OTHERWISE SPECIFIED DIMENSIONS ARE IN INCHES TOLERANCES ARE: .XX ± .01 .XXX ± .005		 LARSON SYSTEMS INC. 10073 Baltimore St. NE PH. 763-780-2131 Mpls., MN 55449 FAX. 763-780-2182	
MATERIAL	-		
FINISH	-	DRAWN	KMP 4/1/04
HEAT TREAT	-	APP.	
		B	DWG. NO. 025-0000-0342-04A
		SCALE: NONE	
		SHEET 1 OF 2	

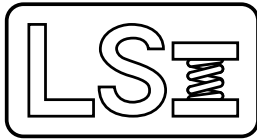

025-0000-0342-04 A

Parts List

Force Meter - DHT 1500 / DHT Carlson Upgrade

Rev	By	Date	Description
	KMP	03-04-2004	
A	DAL	09-07-2007	Delete #16 060-1000-0079-00

Item	Qty	Part Number	Rev	Part Name	PCB Location	Part Length
1	1	018-3000-0018-00		Enclosure, Force Meter		in.
2	1	018-3000-0019-00	A	Cover, Force Meter		in.
3	1	025-0000-0482-00	F	Front Panel Assembly, 2 Line Display (2mv Strain Gage)		in.
4	Opt	025-1000-0261-00	D	Internal RS232 Cable, DHT, CDHT, FDHT, ECT		in.
5	1	025-1000-0493-00		Internal Load Cell Cable DHT 1500, FDHT 1500		in.
6	1	025-1000-0490-00	A	CABLE, INTERNAL ENCODER 6.0"		in.
7	10	013-0000-0077-00		6-32 X 1/4 Button Head Cap Screw		in.
8	4	013-1000-0010-00		Female Screw Lock		in.
9	8	013-0000-0020-00		4-40 X 1/4 Button Head Cap Screw		in.
10	1	025-1000-0251-00	E	Internal Power Cable (025-1000-0396-XX power supplies, Plugs)		in.
10	Opt	025-1000-0491-00		Rechargeable Battery, 6V Kit		in.
11		025-1000-0396-00		Power Supply, 100-240 VAC 50-60 Hz (USA Plug)		in.
11		025-1000-0396-01		Power Supply, 100-240 VAC 50-60 Hz (UK Plug)		in.
11		025-1000-0396-02		Power Supply, 100-240 VAC 50-60 Hz (Australia, New Zealand,		in.
11		025-1000-0396-03		Power Supply, 100-240 VAC 50-60 Hz (Euro Plug)		in.
11		025-1000-0306-02	D	Power Supply, 220 V / 50 Hz, South Africa / India		in.
12	Opt	018-0000-1831-00	B	Battery Retainer for SFM		in.
13	Opt	013-7000-0007-00		White Foam Tape 3.5' X .5" X .25"		in.
14	1	018-0000-1635-00		Power Jack Spacer / Insulator		in.
15	1	018-0000-2160-00	A	Power Jack Nut / Insulator		in.
17	2	013-0000-0004-00		4-40 Hex Nut		in.
18	1	018-0000-2014-00		25 PIN COVER PLATE		in.

Approved by:

Date:

September 7, 2007

SEE ATTACHED DRAWING



Larson Systems Inc.
10073 Baltimore Street NE
Minneapolis, MN 55449-4425
www.larsonsystems.com

763-780-2131
1-877-780-2131
Fax: 763-780-2182
info@larsonsystems.com

